

SPERRY-VICKERS

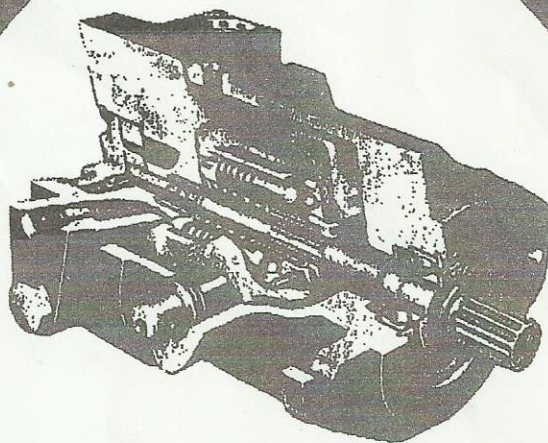

**SERVICE
PARTS
INFORMATION**

TA15 SERIES -10/11 DESIGN

SPERRY - VICKERS
TROY, MI. 48064

Revised 8-1-79

VALVE FLA...		
214118 BRG...		
923212	RIGHT HAN	D 7
923213	LEFT HAN	D 7

REPLENISHING CHECK & RELIEF VALVE (2 REQ'D)	RELIEF VALVE SETTING P.S.I.
323822	2000
323820	2500
339490	3000
322534	3250
317180	4000
318399	4500

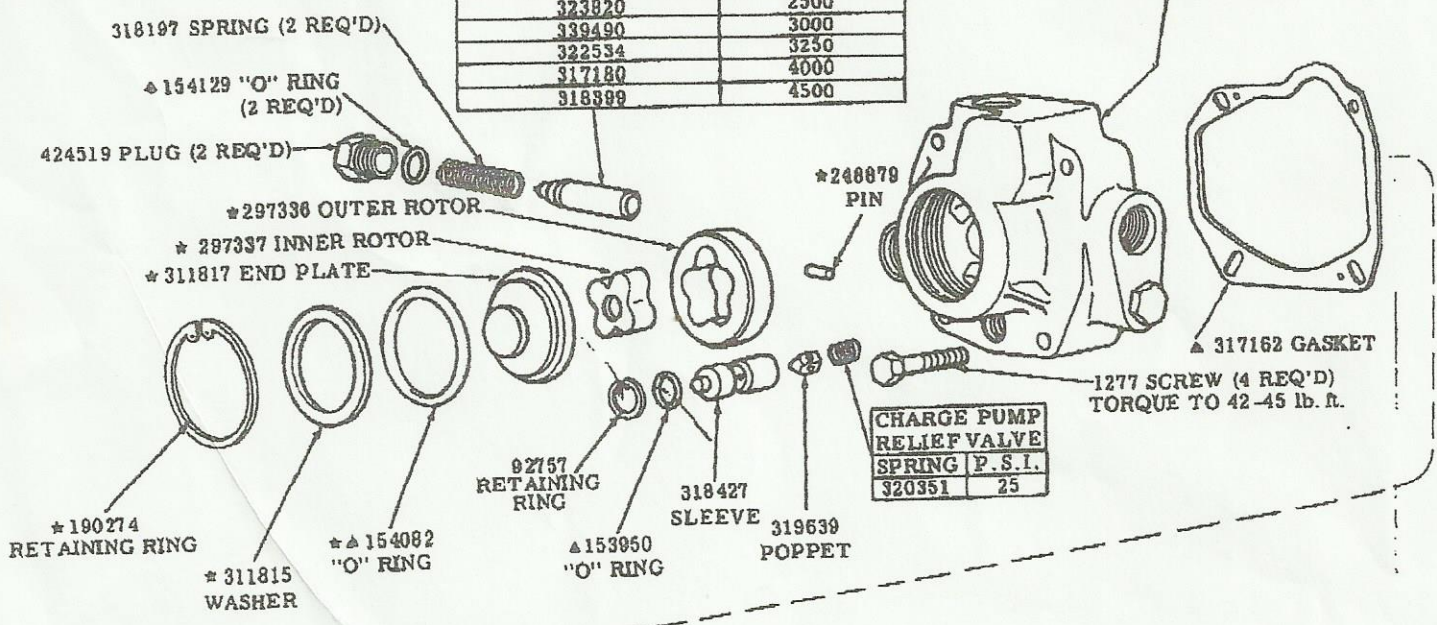

1306 SCREW (2 REQ'D) TORQUE TO 75-80 lb. ft.

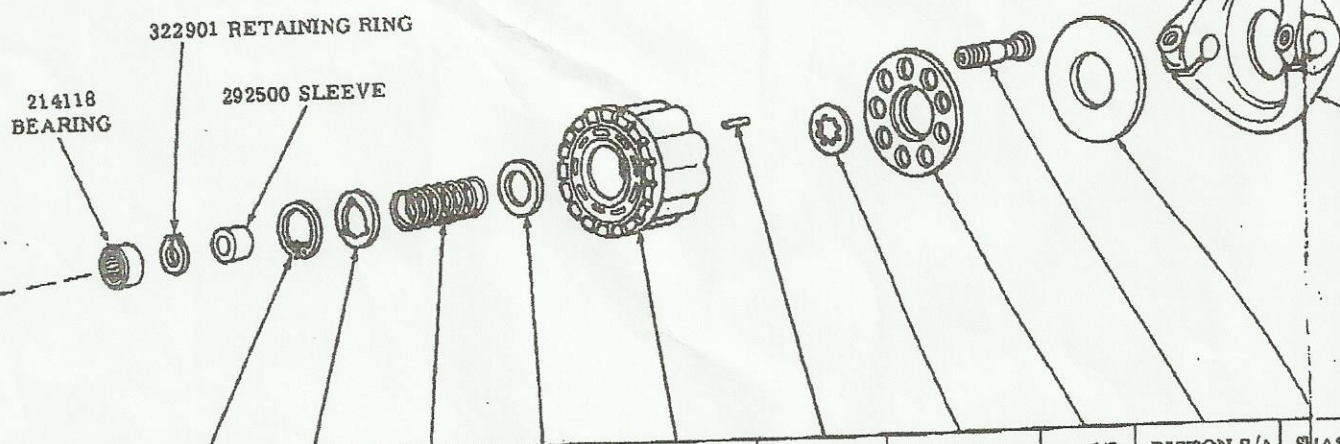

MODEL DESIGNATION	RET. RING	LIFT LIMITER	SPRING	THRUST WASHER	CYLINDER BLOCK	PINS (3 REQ'D)	SPHERICAL WASHER	SHOE PLATE	PISTON S/A (9 PISTONS)	SWASH PLATE
	SERVICED IN PUMP ROTATING GROUP KIT									
TA15-10/11	93509	245223	247294	241954	260860	248811	423324	275961	941887	2907

LT	MODEL
HAN	TA15-**-10/11
HAN	TA15-**-10/11L

ET

LA5-10 LEVER KIT

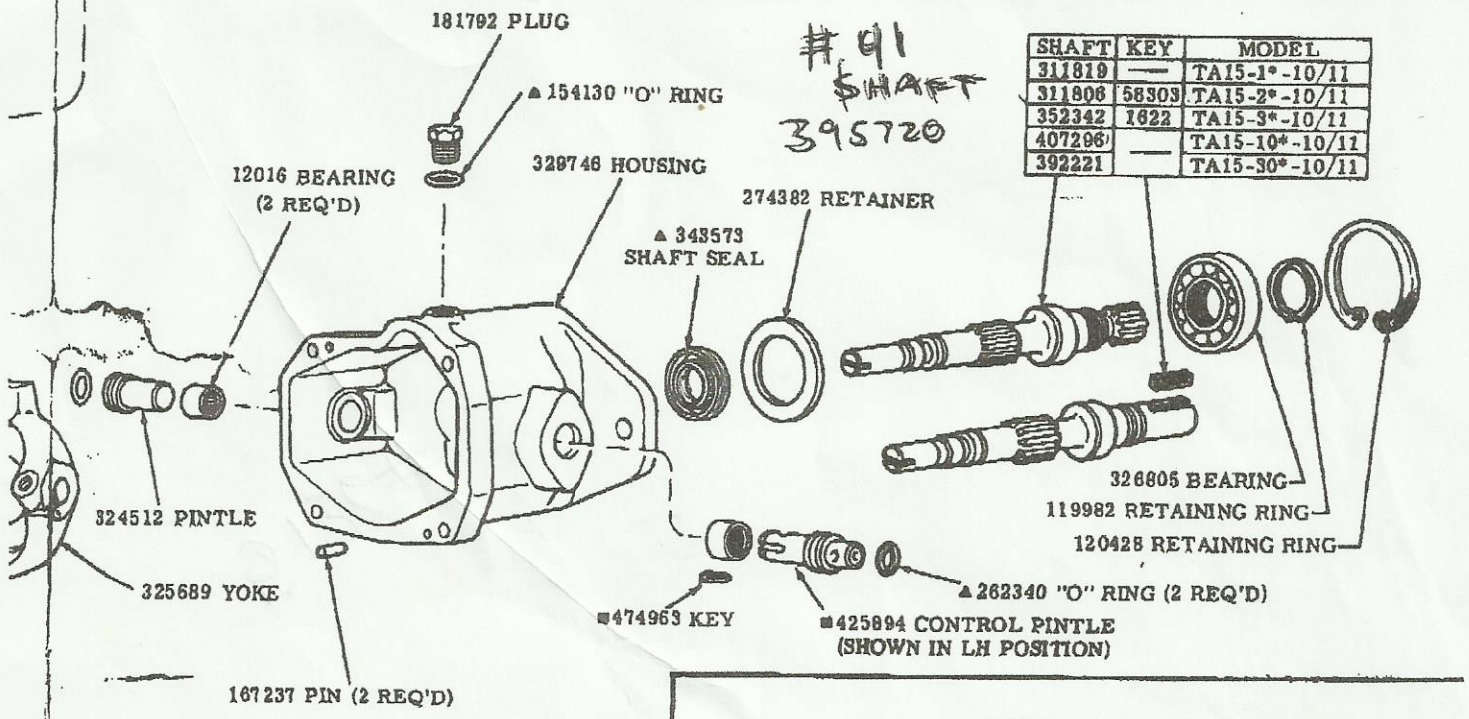
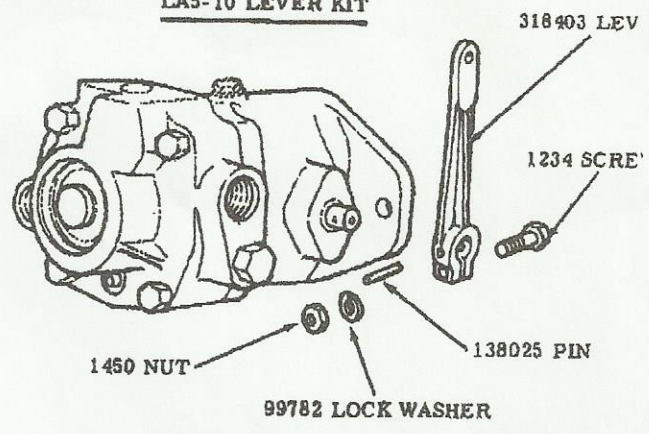

SHAFT KEY	MODEL
311819	TA15-1*-10/11
311808 58303	TA15-2*-10/11
352342 1822	TA15-3*-10/11
407296	TA15-10*-10/11
392221	TA15-30*-10/11

■ -10 DESIGN MUST REPLACE KEY AND CONTROL PINTLE

SWASH PLATE	PUMP ROTATING GROUP KIT
29077	923062

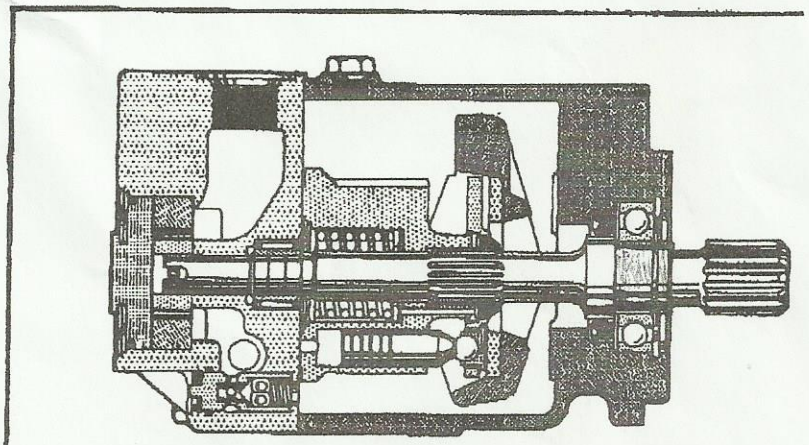

ASSEMBLY VIEW

- ★ THESE PARTS ARE SERVICED IN GEROTOR KIT 923379
- ▲ THESE PARTS ARE INCLUDED IN SEAL KIT 923214

MODEL CODE BREAKDOWN

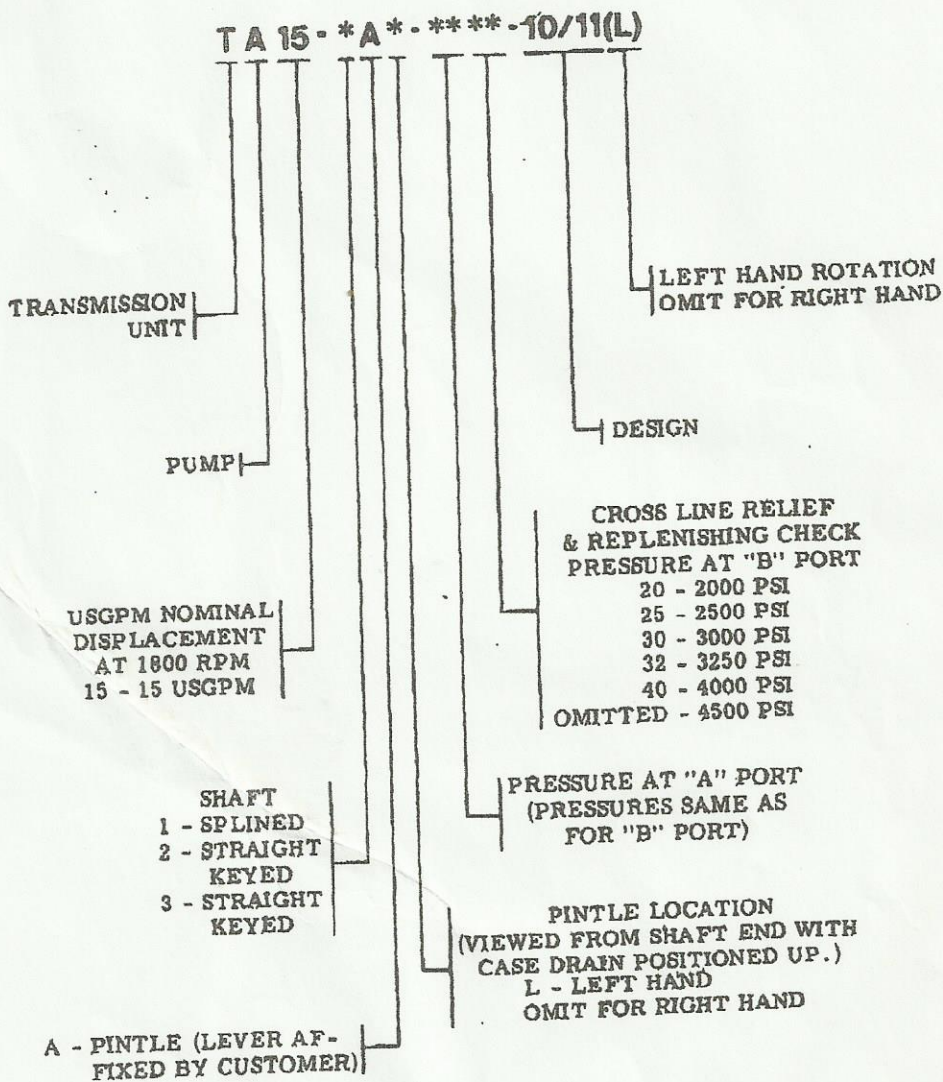

To insure sustained efficiency and maximum trouble-free life of this precision equipment, initial and continuous filtration of the fluid medium to 25 microns absolute or less is essential. (For information pertaining to Sperry Vickers economical 3 or 10 micron filters, see installation drawing 522140.)

Litho in U.S.