

DENISON HYDRAULICS T6CR - T6CRM

vane-type single pump / Flügelzellen-Einzelpumpe
pompe simple à palettes / pompa semplice a palette
tipo bomba de paletas simple
service information



Publ. S1 - ML0512 - A

03 / 2001 / FB

Replace : S1 - ML 062 - C

L25 - 10512 - 1

DENISON | Hydraulics

Recommended repair kits and assy's are bolt printed
 Empfohlene Austausch - Baugruppen sind fett gedruckt
 Les pochettes de rechange recommandées sont imprimées en caractères gras
 I kit di ricambio consigliati sono indicati in grassetto
 Los juegos de reparacion recomendados y los conjuntos, estan en negrita

T6CR

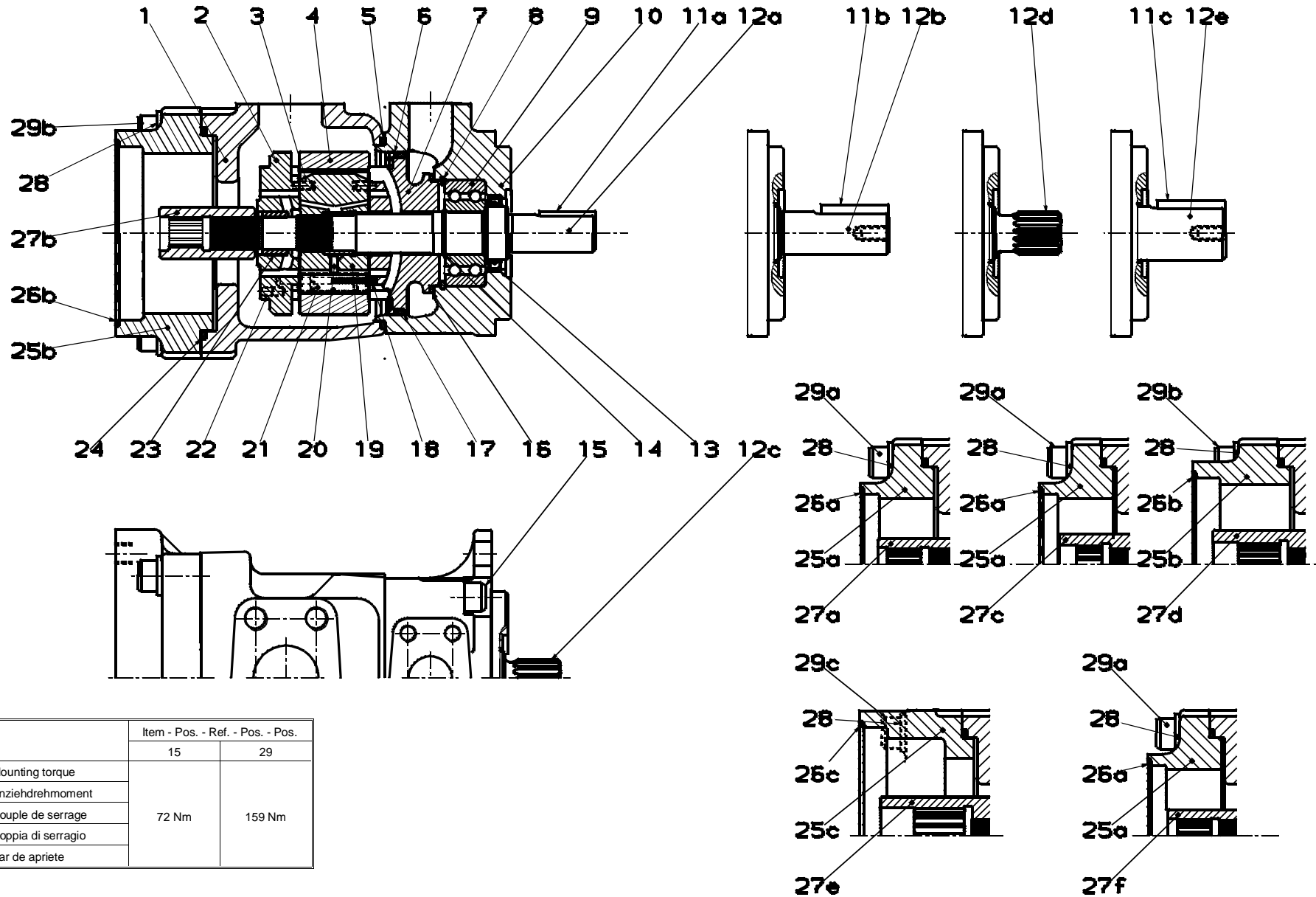

	Item - Pos. - Ref. - Pos. - Pos.	
	15	29
Mounting torque		
Anziehdrehmoment		
Couple de serrage	72 Nm	159 Nm
Coppia di serraggio		
Par de apriete		

Recommended repair kits and assy's are bolt printed
 Empfohlene Austausch - Baugruppen sind fett gedruckt
 Les pochettes de rechange recommandées sont imprimées en caractères gras
 I kit di ricambio consigliati sono indicati in grassetto
 Los juegos de reparacion recomendados y los conjuntos, estan en negrita

T6CRM

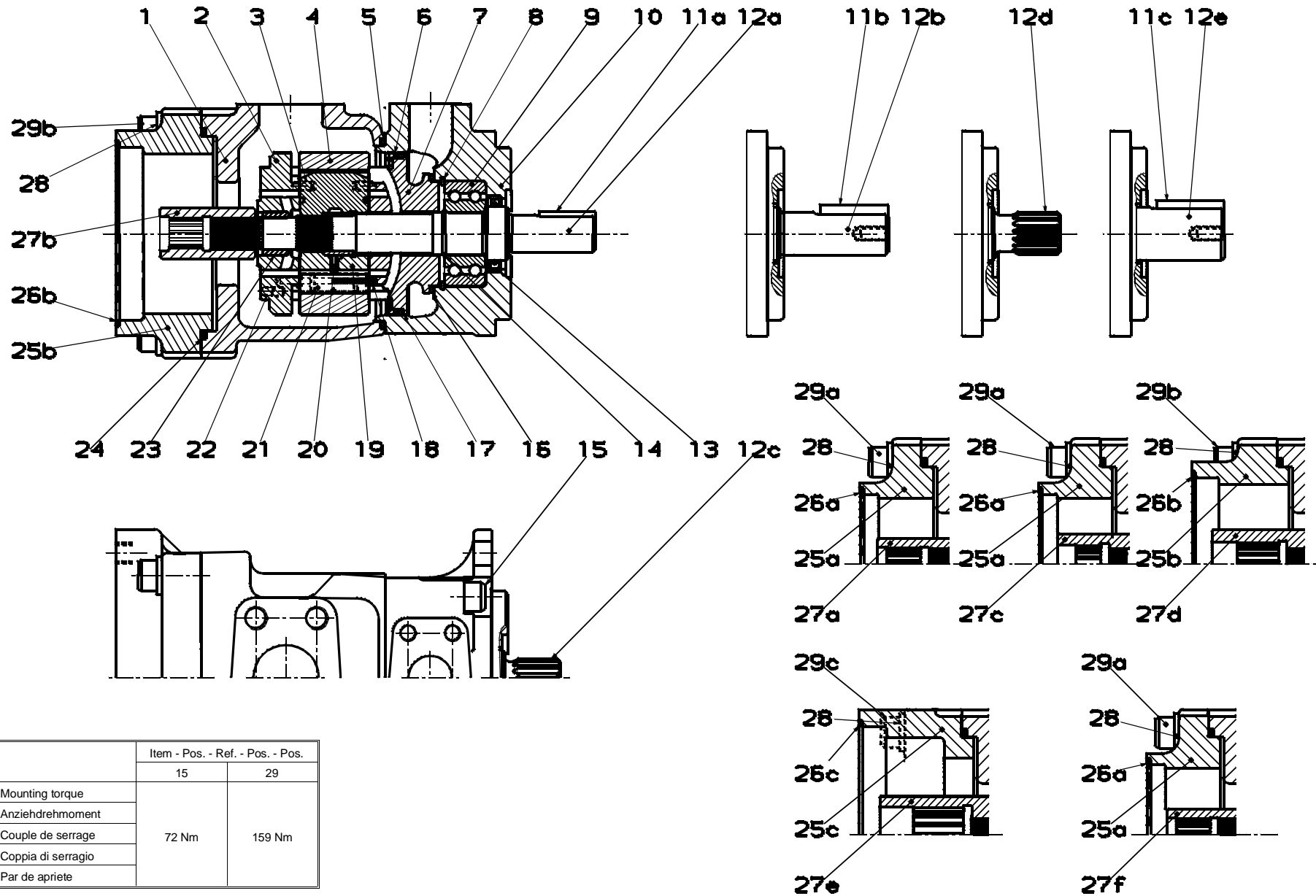

	Item - Pos. - Ref. - Pos. - Pos.	
Mounting torque	15	29
Anziehdrehmoment		
Couple de serrage	72 Nm	159 Nm
Coppia di serraggio		
Par de apriete		

Item Pos. Ref. Pos.	Description <i>Descrizione</i>	Benennung <i>Descripcion</i>	Description		Part N° Teil Nr. Code N° Cod. N° Referencia T6CR	Part N° Teil Nr. Code N° Cod. N° Referencia T6CRM	Qty Stück Qté Q.tà Cant.
1	Housing (standard) <i>Corpo (standard)</i>	Gehäuse (Standard) <i>Cuerpo (estandar)</i>	Carter (standard)		034.66549	034.66549	1
2	Port plate-rear C.C.W. <i>Piatto distributore post. antioraria</i>	Steuerplatte Linkslauf <i>Plato distribuidor trasero giro I</i>	Plaque arrière rotation gauche	AH	034.59777		1
	Port plate-rear C.W. <i>Piatto distributore post. oraria</i>	Steuerplatte Rechtslauf <i>Plato distribuidor trasero giro D</i>	Plaque arrière rotation droite	AI	034.59776		1
	Port plate-rear <i>Piatto distributore post.</i>	Steuerplatte <i>Plato distribuidor trasero</i>	Plaque arrière	AJ		034.59118	1
3	Dowel pin <i>Spina</i>	Zentrierstift <i>Pasador</i>	Goupille	A	324.21208	324.21208	2
4	Cam ring 003 <i>Anello camma 003</i>	Hubring 003 <i>Aro volumetrico 003</i>	Came 003	A	034.59050	034.59050	1
	Cam ring 005 <i>Anello camma 005</i>	Hubring 005 <i>Aro volumetrico 005</i>	Came 005	A	034.59051	034.59051	1
	Cam ring 006 <i>Anello camma 006</i>	Hubring 006 <i>Aro volumetrico 006</i>	Came 006	A	034.59052	034.59052	1
	Cam ring 008 <i>Anello camma 008</i>	Hubring 008 <i>Aro volumetrico 008</i>	Came 008	A	034.59053	034.59053	1
	Cam ring 010 <i>Anello camma 010</i>	Hubring 010 <i>Aro volumetrico 010</i>	Came 010	A	034.59054	034.59054	1
	Cam ring 012 <i>Anello camma 012</i>	Hubring 012 <i>Aro volumetrico 012</i>	Came 012	A	034.66595	034.66595	1
	Cam ring 014 <i>Anello camma 014</i>	Hubring 014 <i>Aro volumetrico 014</i>	Came 014	A	034.59206	034.59206	1
	Cam ring 017 <i>Anello camma 017</i>	Hubring 017 <i>Aro volumetrico 017</i>	Came 017	A	034.59207	034.59207	1
	Cam ring 020 <i>Anello camma 020</i>	Hubring 020 <i>Aro volumetrico 020</i>	Came 020	A	034.66607	034.66607	1
	Cam ring 022 <i>Anello camma 022</i>	Hubring 022 <i>Aro volumetrico 022</i>	Came 022	A	034.59208	034.59208	1
	Cam ring 025 <i>Anello camma 022</i>	Hubring 025 <i>Aro volumetrico 025</i>	Came 025	A	034.59209	034.59209	1
	Cam ring 028 <i>Anello camma 028</i>	Hubring 028 <i>Aro volumetrico 028</i>	Came 028	A	034.59245	034.59245	1
	Cam ring 031 <i>Anello camma 031</i>	Hubring 031 <i>Aro volumetrico 031</i>	Came 031	A	034.66843	034.66843	1
5	O.ring <i>Guarnizione</i>	Dichtring <i>Guarnizione torica</i>	Joint torique	AB	671.00244	671.00244	1
6	Back-up ring <i>Anello anti-estrusione</i>	Stützring <i>Anillo</i>	Bague anti-extrusion	AB	618.15016	618.15016	1
7	Port plate-pressure C.C.W. <i>Piatto distributore anter. antioraria</i>	Steuerplatte Linkslauf <i>Plato distribuidor-presión giro I</i>	Plaque pression rotation gauche	A	034.59773		

Item Pos. Ref. Pos. Pos.	Description <i>Descrizione</i>	Benennung <i>Descripción</i>	Description		Part N° Teil Nr. Code N° Cod. N° Referencia T6CR	Part N° Teil Nr. Code N° Cod. N° Referencia T6CRM	Qty Stück Qtà Cant.
7	Port plate-pressure C.W. <i>Piatto distributore anter. oraria</i>	Steuerplatte Rechtslauf <i>Plato distribuidor-presión giro D</i>	Plaque pression rotation droite	A	034.59772		
	Port plate-pressure <i>Piatto distributore anter.</i>	Steuerplatte <i>Plato distribuidor-presión</i>	Plaque pression	A		034.66453	1
8	Retaining ring <i>Anello elastico</i>	Sicherungsring <i>Anillo de retención</i>	Circlips		356.30244	356.30244	1
9	Ball bearing <i>Cuscinetto a sfere</i>	Kugellager <i>Cojinete de bolas</i>	Roulement à billes	CD EFG	230.90019.3	230.90019.3	1
10	Mounting cap (standard) <i>Coperchio (standard)</i>	Deckel (Standard) <i>Tapa de montaje (estandar)</i>	Chapeau de montage (standard)		034.66566	034.66566	1
11a	Key (code 1) <i>Chiavetta (codice 1)</i>	Paßfeder (Typ 1) <i>Chaveta (codigo 1)</i>	Clavette (code 1)	C	034.48690	034.48690	1
11b	Key (code 2) <i>Chiavetta (codice 2)</i>	Paßfeder (Typ 2) <i>Chaveta (codigo 2)</i>	Clavette (code 2)	D	034.49622	034.49622	1
11c	Key (code 5) <i>Chiavetta (codice 5)</i>	Paßfeder (Typ 5) <i>Chaveta (codigo 5)</i>	Clavette (code 5)	G	034.49676	034.49676	1
12a	Shaft (keyed) (code 1) <i>Albero a chiavetta (codice 1)</i>	Paßfederwelle (Typ 1) <i>Eje chaveteado (codigo 1)</i>	Arbre à clavette (code 1)	C	034.66556	034.66556	1
12b	Shaft (keyed) (code 2) <i>Albero a chiavetta (codice 2)</i>	Paßfederwelle (Typ 2) <i>Eje chaveteado (codigo 2)</i>	Arbre à clavette (code 2)	D	034.66555	034.66555	1
12c	Shaft (splined) (code 3) <i>Albero scanalato (codice 3)</i>	Vielkeilwelle (Typ 3) <i>Eje estriado (codigo 3)</i>	Arbre à cannelures (code 3)	E	034.66557	034.66557	1
12d	Shaft (splined) (code 4) <i>Albero scanalato (codice 4)</i>	Vielkeilwelle (Typ 4) <i>Eje estriado (codigo 4)</i>	Arbre à cannelures (code 4)	F	034.66558	034.66558	1
12e	Shaft (keyed) (code 5) <i>Albero a chiavetta (codice 5)</i>	Paßfederwelle (Typ 5) <i>Eje chaveteado (codigo 5)</i>	Arbre à clavette (code 5)	G	034.66559	034.66559	1
13	Shaft seal (S1 - 0,7 bar) <i>Paraolio (S1 - 0,7 bar)</i>	Simmerring (S1 - 0,7 bar) <i>Reten eje (S1 - 0,7 bar)</i>	Joint d'arbre (S1 - 0,7 bar)	B	620.82046	620.82046	1
	Shaft seal (S4 - 0,7 bar) <i>Paraolio (S4 - 0,7 bar)</i>	Simmerring (S4 - 0,7 bar) <i>Reten eje (S4 - 0,7 bar)</i>	Joint d'arbre (S4 - 0,7 bar)	B	620.82046.4	620.82046.4	1
	Shaft seal (S5 - 0,7 bar) <i>Paraolio (S5 - 0,7 bar)</i>	Simmerring (S5 - 0,7 bar) <i>Reten eje (S5 - 0,7 bar)</i>	Joint d'arbre (S5 - 0,7 bar)	B	620.82046.5	620.82046.5	1
14	Round section ring <i>Anello</i>	Sicherungsring <i>Anillo tórico</i>	Anneau	CD EFG	034.70777	034.70777	1
15	Screw <i>Vite</i>	Schraube <i>Tornille</i>	Vis		358.20320	358.20320	4
16	Sq. section seal <i>Guarnizione</i>	Dichtring <i>Junta seccion cuadrada</i>	Joint section carrée	AB	691.10229	691.10229	1
17	Sq. section seal <i>Guarnizione</i>	Dichtring <i>Junta seccion cuadrada</i>	Joint section carrée	AB	691.10238	691.10238	1
18	Screw <i>Vite</i>	Schraube <i>Tornille</i>	Vis	A	317.06266	317.06266	2

Item Pos. Ref. Pos. Pos.	Description Descrizione	Benennung Descripción	Description		Part N° Teil Nr. Code N° Cod. N° Referencia T6CR	Part N° Teil Nr. Code N° Cod. N° Referencia T6CRM	Qty Stück Qté Q.tà Cant.
19	Rotor-insert ass'y <i>Insieme rotore</i>	Rotor <i>Conjunto rotor</i>	Rotor et douille ass.	A	S24.10350	S24.33974	1
20	Pin-vane holdout <i>Pistoncino di sostentamento</i>	Stössel <i>Espiga empuje paleta</i>	Poussoir de palette	A	034.59098	034.24982	10
21	Vane <i>Paletta</i>	Flügel <i>Paleta</i>	Palette	A	034.59099	034.66716	10
22	Dowel pin <i>Spina</i>	Zentrierstift <i>Pasador</i>	Goupille	A	323.82010	323.82010	1
23	Bush <i>Bussola</i>	Buchse <i>Cojinete de fricción</i>	Bague	AH IJ	034.59412	034.59412	1
24	O.ring <i>Guarnizione</i>	Dichtring <i>Guarnizione torica</i>	Joint torique	B	671.00246	671.00246	1
25a	Mounting adapter (SAE A) <i>Adattatore (SAE A)</i>	Befestigungsflansch (SAE A) <i>Adaptador de montaje (SAE A)</i>	Adaptateur de montage (SAE A)	K	034.67437	034.67437	1
25b	Mounting adapter (SAE B) <i>Adattatore (SAE B)</i>	Befestigungsflansch (SAE B) <i>Adaptador de montaje (SAE B)</i>	Adaptateur de montage (SAE B)	L	034.67438	034.67438	1
25c	Mounting adapter (SAE C) <i>Adattatore (SAE C)</i>	Befestigungsflansch (SAE C) <i>Adaptador de montaje (SAE C)</i>	Adaptateur de montage (SAE C)	M	034.66934	034.66934	1
26a	Sq. section seal <i>Guarnizione</i>	Dichtring <i>Junta seccion cuadrada</i>	Joint section carrée	BK	671.10152	671.10152	1
26b	Sq. section seal <i>Guarnizione</i>	Dichtring <i>Junta seccion cuadrada</i>	Joint section carrée	BL	671.10155	671.10155	1
26c	Sq. section seal <i>Guarnizione</i>	Dichtring <i>Junta seccion cuadrada</i>	Joint section carrée	BM	671.10159	671.10159	1
27a	Coupling (SAE A) (9 teeth) <i>Giunto (SAE A) (9 denti)</i>	Kupplung (SAE A) (zähnezahl 9) <i>Acoplamiento (SAE A) (9 dientes)</i>	Accouplement (SAE A) (9 dents)		034.66537	034.66537	1
27b	Coupling (SAE B) for adapter SAE B <i>Giunto (SAE B) per adattatore SAE B</i>	Kupplung (SAE B) Befestigungsflansch SAE B <i>Acoplamiento (SAE B) para adaptador SAE B</i>	Accouplement (SAE B) pour adaptateur SAE B		034.66540	034.66540	1
27c	Coupling (SAE B) for adapter SAE A <i>Giunto (SAE B) per adattatore SAE A</i>	Kupplung (SAE B) Befestigungsflansch SAE A <i>Acoplamiento (SAE B) para adaptador SAE A</i>	Accouplement (SAE B) pour adaptateur SAE A		034.66649	034.66649	1
27d	Coupling (SAE B-B) <i>Giunto (SAE B-B)</i>	Kupplung (SAE B-B) <i>Acoplamiento (SAE B-B)</i>	Accouplement (SAE B-B)		034.66543	034.66543	1
27e	Coupling (SAE C) <i>Giunto (SAE C)</i>	Kupplung (SAE C) <i>Acoplamiento (SAE C)</i>	Accouplement (SAE C)		034.66546	034.66546	1
27f	Coupling (SAE) (11 teeth) <i>Giunto (SAE) (11 denti)</i>	Kupplung (SAE) (zähnezahl 11) <i>Acoplamiento (SAE - 11dientes)</i>	Accouplement (SAE) (11 dents)		034.66652	034.66652	1
28	Washer <i>Rondella</i>	Scheibe <i>Arandela</i>	Rondelle	KLM	034.66412	034.66412	4
29a	Screw <i>Vite</i>	Schraube <i>Tornille</i>	Vis	K	361.12254.8	361.12254.8	4
29b	Screw <i>Vite</i>	Schraube <i>Tornille</i>	Vis	L	361.12264.3	361.12264.3	4
29c	Screw <i>Vite</i>	Schraube <i>Tornille</i>	Vis	M	361.12284.3	361.12284.3	4

Item Pos. Ref. Pos. Pos.	Description Descrizione	Benennung Description	Description	Part N° Teil Nr. Code N° Cod. N° Referencia T6CR	Part N° Teil Nr. Code N° Cod. N° Referencia T6CRM	Qty Stück Qté Q.tà Cant.
	REPAIR KIT KIT DI RICAMBIO	AUSTAUSCH-BAUGRUPPEN CONJUNTO REPARACION	POCHETTES RECHANGES			
A	Cart. and plate ass'y *03 C.W. <i>Ins. cart. *03 oraria</i>	Pumpeneinheit *03 Rechtslauf <i>Conjunto cart. y platos *03 giro d.</i>	Cart. et plaque ass. *03 rot. d.	S24.26354	S24.44646	1
A	Cart. and plate ass'y *03 C.C.W. <i>Ins. cart. *03 antioraria</i>	Pumpeneinheit *03 Linkslauf <i>Conjunto cart. y platos *03 giro i.</i>	Cart. et plaque ass. *03 rot. g.	S24.26353	S24.44647	1
A	Cart. and plate ass'y *05 C.W. <i>Ins. cart. *05 oraria</i>	Pumpeneinheit *05 Rechtslauf <i>Conjunto cart. y platos *05 giro d.</i>	Cart. et plaque ass. *05 rot. d.	S24.26356	S24.44648	1
A	Cart. and plate ass'y *05 C.C.W. <i>Ins. cart. *05 antioraria</i>	Pumpeneinheit *05 Linkslauf <i>Conjunto cart. y platos *05 giro i.</i>	Cart. et plaque ass. *05 rot. g.	S24.26355	S24.44649	1
A	Cart. and plate ass'y *06 C.W. <i>Ins. cart. *06 oraria</i>	Pumpeneinheit *06 Rechtslauf <i>Conjunto cart. y platos *06 giro d.</i>	Cart. et plaque ass. *06 rot. d.	S24.26358	S24.44650	1
A	Cart. and plate ass'y *06 C.C.W. <i>Ins. cart. *06 antioraria</i>	Pumpeneinheit *06 Linkslauf <i>Conjunto cart. y platos *06 giro i.</i>	Cart. et plaque ass. *06 rot. g.	S24.26357	S24.44651	1
A	Cart. and plate ass'y *08 C.W. <i>Ins. cart. *08 oraria</i>	Pumpeneinheit *08 Rechtslauf <i>Conjunto cart. y platos *08 giro d.</i>	Cart. et plaque ass. *08 rot. d.	S24.26360	S24.44652	1
A	Cart. and plate ass'y *08 C.C.W. <i>Ins. cart. *08 antioraria</i>	Pumpeneinheit *08 Linkslauf <i>Conjunto cart. y platos *08 giro i.</i>	Cart. et plaque ass. *08 rot. g.	S24.26359	S24.44653	1
A	Cart. and plate ass'y *10 C.W. <i>Ins. cart. *10 oraria</i>	Pumpeneinheit *10 Rechtslauf <i>Conjunto cart. y platos *10 giro d.</i>	Cart. et plaque ass. *10 rot. d.	S24.26362	S24.44654	1
A	Cart. and plate ass'y *10 C.C.W. <i>Ins. cart. *10 antioraria</i>	Pumpeneinheit *10 Linkslauf <i>Conjunto cart. y platos *10 giro i.</i>	Cart. et plaque ass. *10 rot. g.	S24.26361	S24.44655	1
A	Cart. and plate ass'y *12 C.W. <i>Ins. cart. *12 oraria</i>	Pumpeneinheit *12 Rechtslauf <i>Conjunto cart. y platos *12 giro d.</i>	Cart. et plaque ass. *12 rot. d.	S24.26383	S24.44656	1
A	Cart. and plate ass'y *12 C.C.W. <i>Ins. cart. *12 antioraria</i>	Pumpeneinheit *12 Linkslauf <i>Conjunto cart. y platos *12 giro i.</i>	Cart. et plaque ass. *12 rot. g.	S24.26382	S24.44657	1
A	Cart. and plate ass'y *14 C.W. <i>Ins. cart. *14 oraria</i>	Pumpeneinheit *14 Rechtslauf <i>Conjunto cart. y platos *14 giro d.</i>	Cart. et plaque ass. *14 rot. d.	S24.26364	S24.44658	1
A	Cart. and plate ass'y *14 C.C.W. <i>Ins. cart. *14 antioraria</i>	Pumpeneinheit *14 Linkslauf <i>Conjunto cart. y platos *14 giro i.</i>	Cart. et plaque ass. *14 rot. g.	S24.26363	S24.44659	1
A	Cart. and plate ass'y *17 C.W. <i>Ins. cart. *17 oraria</i>	Pumpeneinheit *17 Rechtslauf <i>Conjunto cart. y platos *17 giro d.</i>	Cart. et plaque ass. *17 rot. d.	S24.26366	S24.44660	1
A	Cart. and plate ass'y *17 C.C.W. <i>Ins. cart. *17 antioraria</i>	Pumpeneinheit *17 Linkslauf <i>Conjunto cart. y platos *17 giro i.</i>	Cart. et plaque ass. *17 rot. g.	S24.26365	S24.44661	1
A	Cart. and plate ass'y *20 C.W. <i>Ins. cart. *20 oraria</i>	Pumpeneinheit *20 Rechtslauf <i>Conjunto cart. y platos *20 giro d.</i>	Cart. et plaque ass. *20 rot. d.	S24.31885	S24.44662	1
A	Cart. and plate ass'y *20 C.C.W. <i>Ins. cart. *20 antioraria</i>	Pumpeneinheit *20 Linkslauf <i>Conjunto cart. y platos *20 giro i.</i>	Cart. et plaque ass. *20 rot. g.	S24.50391	S24.44663	1
A	Cart. and plate ass'y *22 C.W. <i>Ins. cart. *22 oraria</i>	Pumpeneinheit *22 Rechtslauf <i>Conjunto cart. y platos *22 giro d.</i>	Cart. et plaque ass. *22 rot. d.	S24.26368	S24.44664	1
A	Cart. and plate ass'y *22 C.C.W. <i>Ins. cart. *22 antioraria</i>	Pumpeneinheit *22 Linkslauf <i>Conjunto cart. y platos *22 giro i.</i>	Cart. et plaque ass. *22 rot. g.	S24.26367	S24.44665	1
A	Cart. and plate ass'y *25 C.W. <i>Ins. cart. *25 oraria</i>	Pumpeneinheit *25 Rechtslauf <i>Conjunto cart. y platos *25 giro d.</i>	Cart. et plaque ass. *25 rot. d.	S24.26370	S24.44666	1
A	Cart. and plate ass'y *25 C.C.W. <i>Ins. cart. *25 antioraria</i>	Pumpeneinheit *25 Linkslauf <i>Conjunto cart. y platos *25 giro i.</i>	Cart. et plaque ass. *25 rot. g.	S24.26369	S24.44667	1

Item Pos. Ref. Pos.	Description <i>Descrizione</i>	Benennung <i>Descripcion</i>	Description	Part N° Teil Nr. Code N° Cod. N° Referencia T6CR	Part N° Teil Nr. Code N° Cod. N° Referencia T6CRM	Qty Stück Qté Q.tà Cant.
A	Cart. and plate ass'y *28 C.W. <i>Ins. cart. *28 oraria</i>	Pumpeneinheit *28 Rechtslauf <i>Conjunto cart. y platos *28 giro d.</i>	Cart. et plaque ass. *28 rot. d.	S14.26372	S24.44668	1
A	Cart. and plate ass'y *28 C.C.W. <i>Ins. cart. *28 antioraria</i>	Pumpeneinheit *28 Linkslauf <i>Conjunto cart. y platos *28 giro i.</i>	Cart. et plaque ass. *28 rot. g.	S24.26371	S24.44669	1
A	Cart. and plate ass'y *31 C.W. <i>Ins. cart. *31 oraria</i>	Pumpeneinheit *31 Rechtslauf <i>Conjunto cart. y platos *31 giro d.</i>	Cart. et plaque ass. *31 rot. d.	S24.49442	S24.49345	1
A	Cart. and plate ass'y *31 C.C.W. <i>Ins. cart. *31 antioraria</i>	Pumpeneinheit *31 Linkslauf <i>Conjunto cart. y platos *31 giro i.</i>	Cart. et plaque ass. *31 rot. g.	S24.49443	S24.58015	1
B	Seal kit (S1 - 0,7 bar) <i>Serie guarnizioni (S1 - 0,7 bar)</i>	Dichtringsatz (S1 - 0,7 bar) <i>Juego de juntas (S1 - 0,7 bar)</i>	Pochette de joint (S1 - 0,7 bar)	S24.26387	S24.26387	1
	Seal kit (S4 - 7 bar) <i>Serie guarnizioni (S4 - 7 bar)</i>	Dichtringsatz (S4 - 7 bar) <i>Juego de juntas (S4 - 7 bar)</i>	Pochette de joint (S4 - 7 bar)	S24.26387.4	S24.26387.4	1
	Seal kit (S5 - 7 bar) <i>Serie guarnizioni (S5 - 7 bar)</i>	Dichtringsatz (S5 - 7 bar) <i>Juego de juntas (S5 - 7 bar)</i>	Pochette de joint (S5 - 7 bar)	S24.26387.5	S24.26387.5	1
C	Shaft and bearing ass'y (code 1) <i>Ins. albero (codice 1)</i>	Baugruppe (Welle u. Lager) (Typ 1) <i>Conjunto eje cojinete (codigo 1)</i>	Arbre et roulement ass. (code 1)	S24.26345	S24.26345	1
D	Shaft and bearing ass'y (code 2) <i>Ins. albero (codice 2)</i>	Baugruppe (Welle u. Lager) (Typ 2) <i>Conjunto eje cojinete (codigo 2)</i>	Arbre et roulement ass. (code 2)	S24.26344	S24.26344	1
E	Shaft and bearing ass'y (code 3) <i>Ins. albero (codice 3)</i>	Baugruppe (Welle u. Lager) (Typ 3) <i>Conjunto eje cojinete (codigo 3)</i>	Arbre et roulement ass. (code 3)	S24.26346	S24.26346	1
F	Shaft and bearing ass'y (code 4) <i>Ins. albero (codice 4)</i>	Baugruppe (Welle u. Lager) (Typ 4) <i>Conjunto eje cojinete (codigo 4)</i>	Arbre et roulement ass. (code 4)	S24.26347	S24.26347	1
G	Shaft and bearing ass'y (code 5) <i>Ins. albero (codice 5)</i>	Baugruppe (Welle u. Lager) (Typ 5) <i>Conjunto eje cojinete (codigo 5)</i>	Arbre et roulement ass. (code 5)	S24.26348	S24.26348	1
H	Port plate-rear and bush ass'y C.C.W. <i>Ins. piatto distributore post. antioraria</i>	Steuerplatte mit Buchse Linkslauf <i>Conj. plato dist. tras. con conj. fricción giro I</i>	Plaque ar. et bague ass. rot. gauche	S24.10807		1
I	Port plate-rear and bush ass'y C.W. <i>Ins. piatto distributore post. oraria</i>	Steuerplatte mit Buchse Rechtslauf <i>Conj. plato dist. tras. con conj. fricción giro D</i>	Plaque ar. et bague ass. rot. droite	S24.10808		1
J	Port plate-rear and bush ass'y <i>Ins. piatto distributore post.</i>	Steuerplatte mit Buchse <i>Conj. plato dist. tras. con conj. fricción</i>	Plaque ar. et bague ass.		S24.10349	1
K	Mounting adapter ass'y (SAE A) <i>Ins. adattatore (SAE A)</i>	Befestigungsflansch (nach SAE A) <i>Conj. adaptador de montaje (SAE A)</i>	Adaptateur ass. (SAE A)	S24.73903	S24.73903	1
L	Mounting adapter ass'y (SAE B) <i>Ins. adattatore (SAE B)</i>	Befestigungsflansch (nach SAE B) <i>Conj. adaptador de montaje (SAE B)</i>	Adaptateur ass. (SAE B)	S24.73904	S24.73904	1
M	Mounting adapter ass'y (SAE C) <i>Ins. adattatore (SAE C)</i>	Befestigungsflansch (nach SAE C) <i>Conj. adaptador de montaje (SAE C)</i>	Adaptateur ass. (SAE C)	S24.49851	S24.49851	1
Notes						

Model Code

Model number :

Series _____

One letter can be added to specify special parts in series _____

Cam ring

(Volumetric displacement) (ml/rev)

003 = 10,8
005 = 17,2
006 = 21,3
008 = 26,4
010 = 34,1

Type of shaft

1 = keyed (SAE B)
2 = keyed (no SAE)
3 = splined (SAE B)
4 = splined (SAE B-B)
5 = keyed (no SAE)

Direction of rotation

R = Clockwise
L = Counter-clockwise

Porting combination

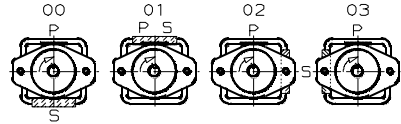

Typenschlüssel

Typenbezeichnung :

Baureihe _____

Optionen _____

geom. Fördervolumen (Flügelzellenpumpe)

(Geometrisches Fördervolumen) (cm³/U)

012 = 37,1
014 = 46,0
017 = 58,3
020 = 63,8

Art der Welle

1 = Paßfederwelle (SAE B)
2 = Paßfederwelle (nicht SAE)
3 = Vielkeilwelle (SAE B)
4 = Vielkeilwelle (SAE B-B)
5 = Paßfederwelle (nicht SAE)

Drehrichtung

R = Rechtslauf
L = Linkslauf

Lage der Anschlüsse

P = Pressure port - Druckanschluß - Orifice de refoulement
S = Suction port - Sauganschluß - Orifice d'aspiration

Adapter

0 = None
A = SAE A
B = SAE B
C = SAE C

Coupling

1 = SAE A (9 teeth)
2 = SAE B
3 = SAE B-B
4 = SAE C
5 = SAE J 498 b 16/32 (11 teeth)

Porting adapter

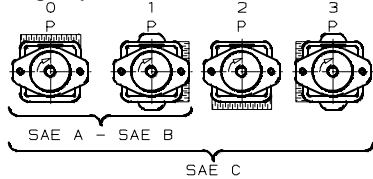

Design letter

Seal class

1 = S1 - BUNA N
4 = S4 - EPDM
5 = S5 - VITON

Modifications

Designation - type

Número du modèle :

Série T6CR - 022 - 1 R 00 - A 20 - A 1 - ..

Une lettre peut être ajoutée pour spécifier les pièces spéciales dans la série.

Came

(Cylindrée théorique) (cm³/tr)

022 = 70,3
025 = 79,3
028 = 88,8
031 = 100,0

Type d'arbre

1 = à clavette (SAE B)
2 = à clavette (non SAE)
3 = à cannelures (SAE B)
4 = à cannelures (SAE B-B)
5 = à clavette (non SAE)

Sens de rotation

R = à droite
L = à gauche

Combinaison des orifices

Adaptateur

0 = Sans
A = SAE A
B = SAE B
C = SAE C

Accouplement

1 = SAE A (9 dents)
2 = SAE B
3 = SAE B-B
4 = SAE C
5 = SAE J498 b 16/32 (11 dents)

Adaptateur de montage

Ausführungsbuchstabe

Dichtungsklasse

1 = S1 - BUNA N
4 = S4 = EPDM
5 = S5 - VITON

Modifikationen

Conception

Classe de joint

1 = S1 - BUNA N
4 = S4 - EPDM
5 = S5 - VITON

Modifications

Designazione

Sigla :

Serie _____

Una lettera può essere aggiunta per specificare parti speciali nella serie _____

Tipo di cartuccia

(Cilindrata) (ml/giro)

- 003 = 10,8
- 005 = 17,2
- 006 = 21,3
- 008 = 26,4
- 010 = 34,1
- 012 = 37,1
- 014 = 46,0

Tipo di albero

- 1 = a chiave (SAE B)
- 2 = a chiave
- 3 = scanalato (SAE B)
- 4 = scanalato (SAE B-B)
- 5 = a chiave

Senso di rotazione

- R = Orario
- L = Antiorario

Orientamento delle bocche

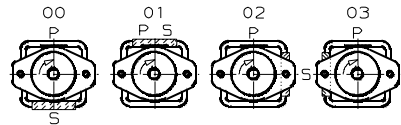

Clave de designación

Referencia modelo :

Serie T6CR - 022 - 1 R 00 - A 20 - A 1 - ..

Una letra puede ser añadida para especificar piezas especiales en la serie _____

Aro volumetrico

(Cilindrada) (ml/rev)

- 017 = 58,3
- 020 = 63,8
- 022 = 70,3
- 025 = 79,3
- 028 = 88,8
- 031 = 100,0

Tipo de eje

- 1 = chaveteado (SAE B)
- 2 = chaveteado (no SAE)
- 3 = estriado (SAE B)
- 4 = estriado (SAE B-B)
- 5 = chaveteado (no SAE)

Sentido de giro

- R = Derecha
- L = Izquierda

Posición de bocas

- P = Mandata - Boca de presión
- S = Aspirazione - Boca de aspiración

Adattatore

- 0 = Senza
- A = SAE A
- B = SAE B
- C = SAE C

Giunto

- 1 = SAE A (9 denti)
- 2 = SAE B
- 3 = SAE B-B
- 4 = SAE C
- 5 = SAE J 498 b 16/32 (11 denti)

Orientamento dell'adattatore

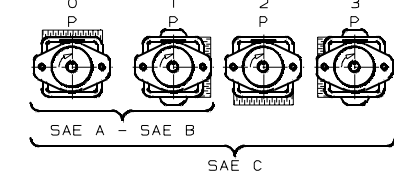

Adaptador

- 0 =
- A = SAE A
- B = SAE B
- C = SAE C

Acoplamiento

- 1 = SAE A (9 dientes)
- 2 = SAE B
- 3 = SAE B-B
- 4 = SAE C
- 5 = SAE J 498 b 16/32 (11 dientes)

Adaptador de montaje

Disegno

Tipo di guarnizioni

- 1 = S1 - BUNA N
- 4 = S4 - EPDM
- 5 = S5 - VITON

Modifiche

Letra de diseño

Clase de juntas

- 1 = S1 - BUNA N
- 4 = S4 - EPDM
- 5 = S5 - VITON

Modificaciones

Model Code

Model number :

Series _____

One letter can be added to specify special parts in series _____

Cam ring

(Volumetric displacement) (ml/rev)

B03 = 10,8
B05 = 17,2
B06 = 21,3
B08 = 26,4
B10 = 34,1

Type of shaft

1 = keyed (SAE B)
2 = keyed (no SAE)
3 = splined (SAE B)
4 = splined (SAE B-B)
5 = keyed (no SAE)

Direction of rotation

R = Clockwise
L = Counter-clockwise

Porting combination

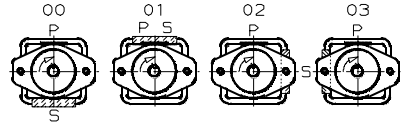

Typenschlüssel

Typenbezeichnung :

Baureihe _____

Optionen _____

geom. Fördervolumen (Flügelzellenpumpe)

(Geometrisches Fördervolumen) (cm³/U)

B12 = 37,1
B14 = 46,0
B17 = 58,3
B20 = 63,8

Art der Welle

1 = Paßfederwelle (SAE B)
2 = Paßfederwelle (nicht SAE)
3 = Vielkeilwelle (SAE B)
4 = Vielkeilwelle (SAE B-B)
5 = Paßfederwelle (nicht SAE)

Drehrichtung

R = Rechtslauf
L = Linkslauf

Lage der Anschlüsse

P = Pressure port - Druckanschluß - Orifice de refoulement
S = Suction port - Sauganschluß - Orifice d'aspiration

Adapter

0 = None
A = SAE A
B = SAE B
C = SAE C

Coupling

1 = SAE A (9 teeth)
2 = SAE B
3 = SAE B-B
4 = SAE C
5 = SAE J 498 b 16/32 (11 teeth)

Porting adapter

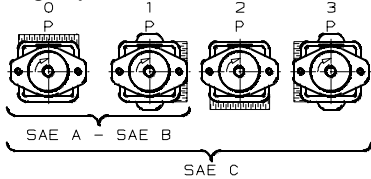

Design letter

Seal class

1 = S1 - BUNA N
4 = S4 - EPDM
5 = S5 - VITON

Modifications

Designation - type

Numéro du modèle :

Série _____

Une lettre peut être ajoutée pour spécifier les pièces spéciales dans la série. _____

Camé

(Cylindree théorique) (cm³/tr)

B22 = 70,3
B25 = 79,3
B28 = 88,8
B31 = 100,0

Type d'arbre

1 = à clavette (SAE B)
2 = à clavette (non SAE)
3 = à cannelures (SAE B)
4 = à cannelures (SAE B-B)
5 = à clavette (non SAE)

Sens de rotation

R = à droite
L = à gauche

Combinaison des orifices

Adaptateur

0 = Sans
A = SAE A
B = SAE B
C = SAE C

Accouplement

1 = SAE A (9 dents)
2 = SAE B
3 = SAE B-B
4 = SAE C
5 = SAE J498 b 16/32 (11 dents)

Adaptateur de montage

Conception

Classe de joint

1 = S1 - BUNA N
4 = S4 - EPDM
5 = S5 - VITON

Modifications

T6CRM . - B22 - 1 R 00 - A 20 - A 1 - ..

Designazione

Sigla :

Serie _____

Una lettera può essere aggiunta per specificare parti speciali nella serie _____

Tipo di cartuccia

(Cilindrata) (ml/giro)

- B03 = 10,8
- B05 = 17,2
- B06 = 21,3
- B08 = 26,4
- B10 = 34,1
- B12 = 37,1
- B14 = 46,0

Tipo di albero

- 1 = a chiave (SAE B)
- 2 = a chiave
- 3 = scanalato (SAE B)
- 4 = scanalato (SAE B-B)
- 5 = a chiave

Senso di rotazione

- R = Orario
- L = Antiorario

Orientamento delle bocche

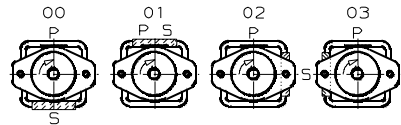

Clave de designación

Referencia modelo :

Serie _____

Una letra puede ser añadida para especificar piezas especiales en la serie _____

Aro volumetrico

(Cilindrada) (ml/rev)

- B17 = 58,3
- B20 = 63,8
- B22 = 70,3
- B25 = 79,3
- B28 = 88,8
- B31 = 100,0

Tipo de eje

- 1 = chaveteado (SAE B)
- 2 = chaveteado (no SAE)
- 3 = estriado (SAE B)
- 4 = estriado (SAE B-B)
- 5 = chaveteado (no SAE)

Sentido de giro

- R = Derecha
- L = Izquierda

Posición de bocas

- P = Mandata - Boca de presión
- S = Aspirazione - Boca de aspiración

Adattatore

- 0 = Senza
- A = SAE A
- B = SAE B
- C = SAE C

Giunto

- 1 = SAE A (9 denti)
- 2 = SAE B
- 3 = SAE B-B
- 4 = SAE C
- 5 = SAE J 498 b 16/32 (11 denti)

Orientamento dell'adattatore

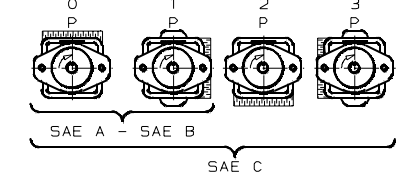

Disegno

Tipo di guarnizioni

- 1 = S1 - BUNA N
- 4 = S4 - EPDM
- 5 = S5 - VITON

Modifiche

Adaptador

- 0 =
- A = SAE A
- B = SAE B
- C = SAE C

Acoplamiento

- 1 = SAE A (9 dientes)
- 2 = SAE B
- 3 = SAE B-B
- 4 = SAE C
- 5 = SAE J 498 b 16/32 (11 dientes)

Adaptador de montaje

Letra de diseño

Clase de juntas

- 1 = S1 - BUNA N
- 4 = S4 - EPDM
- 5 = S5 - VITON

Modificaciones

T6CRM - B22 - 1 R 00 - A 20 - A 1 - ..