

**Abex**

**DENISON**

**SERVICE LITERATURE**

**VANE TYPE PUMP SERIES T5D & T5SD**

**MODEL "C"  
INSTALLATION, OPERATION  
AND  
OVERHAUL INSTRUCTIONS**

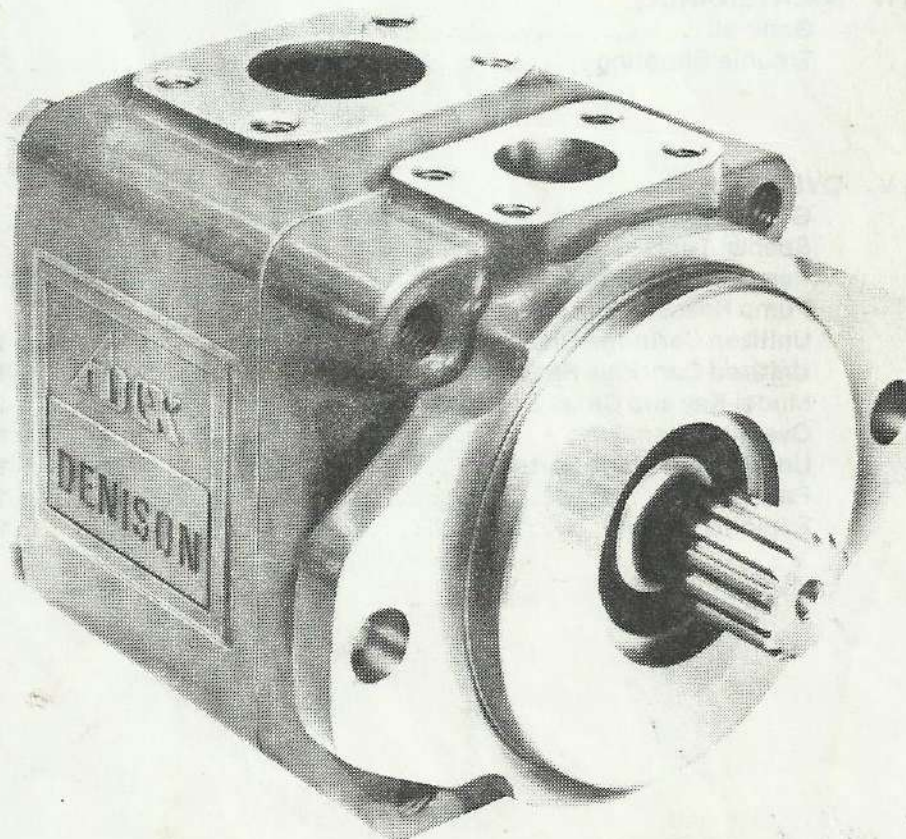

**Vane Type Pump — Series T5D & T5SD**

# Table of Contents

Section I	INTRODUCTION AND DESCRIPTION	
	General.....	3
	Description.....	3
	Theory of Operation.....	3
Section II	INSTALLATION	
	Mounting.....	5
	Piping.....	5
	Fluids.....	5
	Pump Inlet Conditions.....	6
Section III	OPERATING INSTRUCTIONS	
	Pre-Start Check.....	6
	Priming.....	6
Section IV	MAINTENANCE	
	General.....	7
	Trouble Shooting.....	7
Section V	OVERHAUL	
	General.....	8
	Special Tools.....	8
	Pump Disassembly.....	9
	Pump Reassembly.....	9
	Unitized Cartridge Disassembly.....	10
	Unitized Cartridge Reassembly.....	10
	Model Key and Cross Section View.....	11
	Overall Dimensions.....	12
	Unitized Cartridge Parts List.....	13
	Parts List.....	14
	Exploded View.....	15

## Section I INTRODUCTION AND DESCRIPTION

### GENERAL

This manual covers installation, operation, maintenance and overhaul instructions for the Abex/Denison Model C T5D series vane type hydraulic pumps. With improvements made to the port plates and vanes, the Model C T5D series which replaces the Model A series reflects the latest design innovations resulting in increased durability and extended service life.

As of January 1, 1979 Model A T5D series pumps and associated service parts will no longer be manufactured. The transition to the Model C series will not affect parts interchangeability and users of Model A pumps will encounter no difficulty in assembly or repair procedures if parts replacement becomes necessary.

Pump model can be determined by referring to the design letter column of the model number code on page 11.

See page 8 for parts identification and interchangeability.

### DESCRIPTION

The Denison T5D and T5SD vane pumps are efficient, compact units designed for continuous duty up to 3000 PSI and 2500 RPM and intermittent duty up to 3500 PSI.<sup>1</sup>

Six models are offered in this series and supply rated deliveries of 28, 31, 35, 38, 42 and 45 GPM at 1200 RPM at 100 PSI. Refer to table I for detailed operating characteristics.

The T5D and T5SD vane pumps consist of four basic components: (A) housing or body, (B) unitized cartridge consisting of: rotor, vanes, vane hold-out pins, cam ring, bearing and port plates, (C) shaft and bearing and (D) mounting cap. (see fig. 1)

The T5D and T5SD vane pumps feature the use of a unitized pumping cartridge which allows for ease of disassembly and assembly when it becomes necessary to make changes or perform repair in the field. Since the unitized cartridge assembly is pre-tested, it is only necessary to install the cartridge and reassemble the housing and mounting flange.

### THEORY OF OPERATION

The pumping operation of this unit is obtained by providing a fixed interior cam surface and ro-

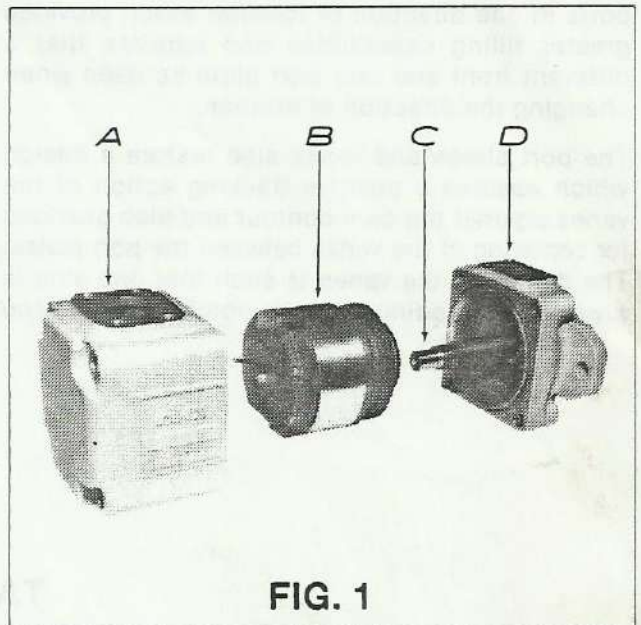

FIG. 1

tating inner member (rotor) containing vanes which are held in contact with the inner cam surface. As the rotor rotates, the vanes are urged against the outward sloping cam surface, forming a cavity at the inlet ports of the port plates. Atmospheric pressure and suction created by the rotating vanes fill the inlet cavity with fluid.

As the rotation continues, the vanes that had previously moved outward and now have fluid trapped between them, follow the inward slope of the cam which decreases the cavity, compresses the fluid therein and discharges the fluid through the pressure ports in the port plates.

The rotating portion of the unitized cartridge features the use of pressure actuated vanes which are urged against the cam ring by hollow pins located in each rotor slot. Initial force to bring the vanes in contact with the cam contour during start up is provided by centrifugal force. The instant hydraulic pressure is obtained, the pins instantaneously separate from the bottom of the vanes in the pressure quadrant and allows fluid to fill the cavity under the pins until the pressure build up essentially equals the system operating pressure which, in turn, provides the force necessary to keep the vanes in contact with the cam ring contour.

### NOTE

When operating at the maximum outlet pressure, the pump shaft rotation should not be allowed to fall below 600 RPM in order to maintain proper vane to cam ring contact.

<sup>1</sup>Ratings shown apply only to the T5D pump when using hydraulic fluid containing anti-wear additives.

Denotes Change

The inlet or suction flow feeds through the 2" port in the housing, through the large ports of each port plate and through the center hole in the suction quadrant of the cam ring. The port plates also feature extended under vane suction ports in one direction of rotation which provides greater filling capabilities and requires that a different front and rear port plate be used when changing the direction of rotation.

The port plates and vanes also feature a design which assures a positive tracking action of the vanes against the cam contour and also provides for centering of the vanes between the port plates. The design of the vanes is such that one side is always the leading side (a notch on the vane

corner identifies the leading edge) and in the event the direction of rotation is reversed the vanes must be reversed. It is also necessary to flip the cam ring 180° when reversing the direction of rotation.

Initial axial clamping pressure is provided to the port plates and cam ring by means of a square section seal under the pressure plate. The instant system pressure is obtained, internal hydraulic pressure proportional to system pressure provides the necessary force required to maintain axial port plate and cam ring clamping.

To determine the performance characteristics of a given model, refer to Table I below:

**TABLE I**  
**THEORETICAL OPERATION CHARACTERISTICS (T5D only)**

Basic Model	Displ. in 3/rev	Speed Rev/min	Delivery* at 100 PSI gal/min	Delivery* at 2500 PSI gal/min	Input H.P. vs. Pressure		
					1000 PSI	2000 PSI	3000 PSI
T5D-028	5.48	1200	28.0	23.0	17.0	34.4	49.4
		1800	42.0	37.0	28.0	53.2	79.2
		2500	58.4	53.4	39.0	74.0	110.0
T5D-031	6.05	1200	31.0	26.0	19.0	38.4	56.8
		1800	46.5	41.5	30.4	58.0	86.2
		2500	64.5	59.5	42.2	80.6	119.8
T5D-035	6.83	1200	35.0	30.0	22.0	43.0	64.0
		1800	52.5	47.5	34.6	65.6	97.4
		2500	72.9	67.9	48.0	91.0	135.2
T5D-038	7.40	1200	38.0	33.0	23.2	46.6	69.6
		1800	57.0	52.0	37.2	71.6	106.0
		2500	79.1	74.1	51.6	99.4	147.2
T5D-042	8.17	1200	42.0	37.0	26.6	51.2	76.8
		1800	63.0	58.0	40.6	78.4	116.8
		2500	87.5	82.5	56.4	109.0	162.0
T5D-045	8.76	1200	45.0	40.0	28.5	54.9	82.3
		1800	67.5	62.5	43.5	84.0	125.0
		2500	93.7	88.6	60.5	116.9	173.5

\*GPM delivery indicated are average values obtained when using a hydraulic fluid of 150 SUS @ 100° F at an operating temperature of 125° F to 135° F.

## Section II INSTALLATION

### MOUNTING

This pump may be mounted in any position, however, it is recommended that a horizontal position be used whenever possible. The inlet and outlet port arrangement allows four relative positions in 90° intervals. If desired, the porting relationship may be changed by removing the four bolts securing the housing to the mounting cap and rotating the housing and mounting cap to the desired porting arrangement. When replacing the four bolts, they must be torqued to the recommended value. (135 ft. lbs.) The mounting hub and bolt hole location conform to SAE-C, 2-bolt standard in both the spline and key shaft options. The pump shaft must be in alignment with the power source shaft and should be checked with a dial indicator. The mounting pad or adapter into which the pump pilots must be concentric with the power source shaft within 0.006 TIR. This concentricity is particularly important if the pump shaft is rigidly connected to the power source without a flexible coupling.

### PIPING

All fluid lines either pipe, tubing or hose, must be of adequate size and strength to assure free flow to and from the pump. *Do Not Use Galvanized Pipe.* Galvanized coating can flake off after continued use. An undersize inlet line will restrict the fluid flow to the pump and prevent proper operation and may cause damage due to cavitation. Inlet piping must be sized to meet or exceed minimum inlet requirements as outlined in Table II and Table III. If rigid pipe or tubing is used, the workmanship must be accurate in order to eliminate strain on the pump housing or mounting cap or the fluid connectors. Sharp bends in the lines should be eliminated whenever possible. All system piping must be cleaned with solvent or equivalent cleaning agent before connecting to the pump.

### TABLE II

**Inlet Pressure, Minimum T5D** — as measured at pump inlet flange with petroleum base fluids. Multiply absolute pressures by multiplier shown in table IV to find inlet pressures for fire resistant fluids.

Speed	Gauge Pressure				Absolute Pressure	
	PSIG	Bar	in. Hg.	mm Hg.	PSIA	Bar
1200	-3	-0.20	(-1)6	(-1)52	8.0	0.55
1500	-3	-0.20	(-1)6	(-1)52	9.0	0.62
1800	-3	-0.20	(-1)6	(-1)52	10.5	0.72
2500	0*	0*	0*	0*	14.5*	1.0*

\*Except for pumps with 045 cam rings which are rated as follows with their 2500 rpm max.

2500	+0.5	+0.03	+1.0	+25	15.2	1.05
------	------	-------	------	-----	------	------

### TABLE III

**Inlet Pressure, Minimum T5SD** — as measured at pump inlet flange with petroleum base fluids. Multiply absolute pressures by multiplier shown in table IV to find inlet pressures for fire resistant fluids.

Speed	Gauge Pressure				Absolute Pressure	
	PSIG	Bar	in. Hg.	mm Hg.	PSIA	Bar
1200	-3	-0.20	(-1)6	(-1)52	8	0.55
1500	-3	-0.20	(-1)6	(-1)52	9	0.62
1800	0	0	0	0	14.5	1.0
2000	3.5	0.24	+7	179	18	1.24
2200	7	0.48	+14	356	21.5	1.48
2500	14	0.97	+28	711	28.5	1.97

### TABLE IV

Fluid Type†	Denison Spec.	Pump Series Usable	Max. Temp		Max System Pressure		Suction Pressure Multiplier
			°F	°C	PSI	Bar	
Antiwear Petroleum Base Fluids for Severe Duty	HF-0	T5, T5S	210	100	3000	207	1.0
Antiwear Petroleum Base Fluids	HF-2	T5, T5S	210	100	3000	207	1.0
Non-antiwear Petroleum Base Fluids	HF-1	T5, T5S	210	100	2500	172	1.0
Crankcase Oils	HF-6	T5, T5S	210	100	3000	207	1.0
Water-in-Oil Invert Emulsions	HF-3	T5S only	120	49	2500	172	1.25
Water Glycols	HF-4	T5S only	120	49	2000	138	1.25
Synthetic Fluids (Phosphate Ester & Others)	HF-5	T5S only	160	71	2500	172	1.35

†See Denison Fluids Bulletin 2002 for further information.

### TABLE V OPERATING SPECIFICATIONS

Fluid Type	Denison Fluid Spec.	T5D Continuous			**T5D Intermittent			T5SD Continuous			**T5SD Intermittent		
		Speed RPM	Pressure		Speed RPM	Pressure		Speed RPM	Pressure		Speed RPM	Pressure	
			PSI	Bar		PSI	Bar		PSI	Bar		PSI	Bar
Antiwear Petroleum Base	HF-0	2500	2500	172	2500	3000	207	2500	3000	207	2500	3500	241
	HF-2	2500	2500	172	2500	3000	207	2500	2500	172	2500	3000	207
Crankcase Oils	HF-6	2500	2500	172	2500	3000	207	2500	2500	172	2500	3000	207
*Non Antiwear Petroleum Base	HF-1	2500	2000	138	2500	2500	172	2500	2500	172	2500	3000	207
Water-in-Oil Emulsions	HF-3	—	—	—	—	—	—	1800	2000	138	1800	2500	172
Water Glycols	HF-4	—	—	—	—	—	—	1800	2000	138	1800	2500	172
Synthetic Fluids	HF-5	—	—	—	—	—	—	1800	2500	172	1800	3000	207

\*Petroleum base fluid without anti-wear additives is not recommended, however, if used the reduced ratings listed apply.

\*\*Pressure indicated is not to exceed 12 seconds per minute of operation.

## FLUIDS

**Type** — It is recommended that fluid used in the T5D pump have a petroleum base and contain agents which provide oxidation inhibition and anti-rust, anti-foam and de-aerating properties.

**Anti-wear additives** — It is strongly recommended that fluid used contain the necessary additives to secure high anti-wear characteristics. Comparative operating pressure and speed limits for anti-wear and non-anti-wear fluids are shown in Table V.

**Automotive Crankcase Oils** — Certain types of these fluids (API Service Class MS or new API class SC, SD or SE) contain detergents, anti-wear additives and other properties as previously specified. The fact that detergents tend to hold water in suspension as an emulsion may cause precipitates to form which might contribute to filtration problems. These fluids may be used only if little or no water is present.

**Non-petroleum Base or Fire-Resistant Fluids** — When it becomes necessary to use these types of fluids, the T5SD pump should be used on some types (Fyrul 220 or equivalent) and must be used with other fire-resistant fluids. To determine performance characteristics or ratings for a particular fluid, a Denison Sales Representative should be consulted.

**Operating Temperature** — For the most efficient pump operation, refer to Table IV.

## PUMP INLET CONDITIONS

During pump operation, the inlet conditions must be sufficient to provide filling without cavitation. The use of an improper grade of oil, improper or restrictive inlet piping may result in an inlet vacuum in excess of recommendations and will reduce the pump service life or may cause damage to the pump parts. An inlet pressure of 1 to 10 PSIG is desirable. During high speed operation, it is particularly important to provide proper inlet pressures. If a pressurized or boosted inlet system is used, the inlet pressure must not exceed 35 PSIG.

Refer to Tables II and III for minimum inlet requirements.

### NOTE

When an inlet strainer is used, it should have a minimum capacity equal to twice the GPM output of the pump.

## FLUID CLEANLINESS

The fluid must be cleaned before and during operation to maintain a contamination level of NAS 1638 class 8 (or SAE class 4) or better. Filters with 25 micron (or, better, 10 micron) nominal ratings may be adequate but do not guarantee the required cleanliness levels.

Suction strainers must be of size adequate to provide minimum inlet pressure specified. 100 mesh (149 micron) is the finest mesh recommended. Use oversize strainers or omit them altogether on applications which require cold starts or use fire resistant fluids.

## Section III OPERATING INSTRUCTIONS

### PRE-START CHECK

Before initial starting of the pump, the following checks should be made.

- a. Check the rotation of the power source to be sure the pump will rotate in the direction indicated by the arrow on the pump identification tag.
- b. Check inlet and discharge to be sure all connections are tight and connected properly.
- c. Check all mounting bolts and flanges to be sure they are tight and properly aligned.
- d. When possible the pump shaft should be rotated by hand to assure that it rotates freely.

### PRIMING

If the pump is installed with a positive head on

the inlet, priming will be instantaneous upon start up. It is recommended that a minimum pump shaft speed of 600 RPM be obtained for priming, however, this speed will vary with different inlet and outlet conditions. When a pressure relief valve is used at the outlet, it should be backed off to the minimum setting. When possible, an air bleed off should be provided in the circuit to facilitate purging the system of air. When it is not possible or practical to provide a positive head the pump inlet or the installation is such that a suction lift results, the following procedure is recommended.

- a. Manually fill the pump housing with fluid.
- b. Start rotation in a jogging manner until a prime is picked up.
- c. Bleed off air that may become trapped in the pump.

To prevent possible damage to the internal parts, the pump should never be started dry or without internal lubrication.

## NOTE

If the pump does not prime properly or pressure cannot be obtained, it should be shut down and condition corrected.

## Section IV MAINTENANCE

### GENERAL

The internal parts of this pump are lubricated by the operating fluid, therefore, preventative maintenance is limited to keeping the fluid in the system clean. The system filters should be replaced frequently and if a suction strainer is used it must not be allowed to become restricted. When possible, dirt should not be allowed to accumulate on the pump or around the shaft seal. All

fittings and bolts should be tight.

## NOTE

It is especially important that the suction or inlet piping and fittings be tight and in good repair to prevent air from being drawn into the system.

In the event the pump does not perform properly or a malfunction occurs, refer to the "Trouble Shooting Chart" before proceeding with an overhaul.

**TABLE VI  
TROUBLE SHOOTING**

Trouble	Probable Cause	Possible Remedy
External Leakage	<ul style="list-style-type: none"> <li>a. Seal failure</li> <li>b. Porosity in casting</li> <li>c. Damaged or defective seal between housing and mounting cap.</li> </ul>	<ul style="list-style-type: none"> <li>a. Replace seal.</li> <li>b. Replace casting.</li> <li>c. Replace seal.</li> </ul>
Leakage at Fittings	<ul style="list-style-type: none"> <li>a. Cracked or damaged flange or fittings.</li> <li>b. Damaged or defective flange threads.</li> <li>c. Damaged or defective "O" ring seal.</li> <li>d. Burr on mating surfaces.</li> </ul>	<ul style="list-style-type: none"> <li>a. Replace flange or fittings.</li> <li>b. Replace flange.</li> <li>c. Replace "O" ring seal.</li> <li>d. Remove burr.</li> </ul>
Loss In Pump RPM Under Load.	<ul style="list-style-type: none"> <li>a. Power source too small for pump being used.</li> </ul>	<ul style="list-style-type: none"> <li>a. Provide larger power source.</li> </ul>
Pump Not Delivering Oil	<ul style="list-style-type: none"> <li>a. Pump does not prime.</li> <li>b. Wrong direction on shaft rotation.</li> <li>c. Tank fluid level too low.</li> <li>d. Fluid inlet line or suction strainer clogged as undersized.</li> <li>e. Air leak in suction line.</li> <li>f. Fluid viscosity too heavy to pick up prime.</li> <li>g. Broken pump shaft or internal parts.</li> </ul>	<ul style="list-style-type: none"> <li>a. Bleed air from system.</li> <li>b. Reverse direction of shaft. Convert pump to reverse direction of rotation. (Check rotation arrows on ident. plate &amp; cam ring.)</li> <li>c. Add fluid and check level to be certain suction line is submerged.</li> <li>d. Clean strainer of all foreign material. Provide proper size strainer (should have a capacity equal to 2 times pump volume in GPM).</li> <li>e. Tighten and seal connections. Replace seals.</li> <li>f. Use lighter viscosity fluid.</li> <li>g. Replace damaged parts per overhaul instructions.</li> </ul>
Pump Not Developing Pressure	<ul style="list-style-type: none"> <li>a. Relief valve setting too low.</li> <li>b. Relief valve sticking open.</li> <li>c. Vane hold out pins not loading vanes.</li> <li>d. Free recirculation of fluid to tank being allowed.</li> </ul>	<ul style="list-style-type: none"> <li>a. Reset relief valve.</li> <li>b. Check for defective or malfunctioning valve.</li> <li>c. Disassemble and check pins &amp; pin bores for burrs or damage: Check for foreign material.</li> <li>d. Check directional control valve for open center or neutral position. Check for open bypass valve.</li> </ul>

**TABLE VI — TROUBLESHOOTING (cont'd)**

Trouble	Probable Cause	Possible Remedy
Noisy or Erratic Operation	<p>a. Air leak at pump inlet or suction lines.</p> <p>b. Housing and mounting cap separation.</p> <p>c. Restricted or clogged inlet line or strainer.</p> <p>d. Excessive pump RPM (cavitation).</p> <p>e. Worn vanes, cam ring or port plates.</p> <p>f. Worn vane holdout pins or clogged oil feed holes in pins.</p> <p>g. Worn bearings.</p>	<p>a. Check for air leaks by pouring system fluid around joints and listen for change in sound level. Tighten as required.</p> <p>b. Check bolts for proper torque.</p> <p>c. Provide larger inlet line or strainer. Clean strainer.</p> <p>d. Provide power source that does not exceed maximum pump RPM recommendations.</p> <p>e. Disassemble per overhaul instructions and replace worn parts.</p> <p>f. Disassemble per overhaul instructions. Replace pins if worn or clean if clogged.</p> <p>g. Disassemble and replace.</p>
Seal Failure	a. Excessive inlet pressure.	a. Decrease inlet pressure. Inlet pressure must not exceed 35 PSI.#

Problems encountered not indicated in this table should be referred to the Customer Service Center or nearest Abex/Denison representative.

#Except pumps with S5 seals, these must not exceed 50 PSI.

## Section V OVERHAUL

### GENERAL

The instructions contained in this section cover complete disassembly, inspection and reassembly of the Abex/Denison Model C T5D series vane type pump. As noted in the introduction on page 3, effective January 1, 1979 the Model A T5D series and related service parts will no longer be available.

The Model A T5D series will be replaced by the Model C Series (T5D, T5SD) featuring redesigned vanes and port plates resulting in increased durability and extended service life of the units.

Since these design changes do not affect parts interchangeability, all Model A units may be serviced and/or updated using Model C parts and the T5QD, which has been discontinued, can be serviced with Model C series T5D parts. On Model A series pumps it is recommended that the entire cartridge be replaced when either the port plates or vanes require replacement. Except the redesigned vanes and port plates all other parts are identical between the two model series. Below is a summary of changes to the affected parts and how to distinguish Model A from Model C parts.

**Vaness—** Model C vanes can easily be identified by the two drain holes drilled into the trailing side of the vane (opposite the chamfer indicating leading edge). Model A vanes have no drain holes.

**Pressure and Rear Port Plates—**C model port plates are identified by two  $\frac{1}{8}$ " holes drilled in the pressure ramp area of the pressure plate only (see figures IV and V).

Model A plates do not have these drilled holes. It must be noted that on Model A pumps, replacement of both port plates is mandatory when servicing with Model C parts.

Sometimes a malfunction can be corrected without removing the pump from the installation by replacing the cartridge assembly. This can be accomplished by removing the four housing screws and removing the rear housing.

1. Drain all fluid from the pump and thoroughly clean the exterior surface.
2. Prepare a clean, lint free surface on which to lay the internal parts for inspection and repair.

### SPECIAL TOOLS

Special tools are required to properly install the shaft oil seal. A shaft seal driver of proper size must be used to install the shaft seal. A protective cone must be used over the shaft end to prevent damage to the shaft seal when installing the shaft. The remainder of the pump disassembly and assembly can be accomplished with normal repair shop tools and good repair practices. Refer to Figure II for proper configuration and dimensions for the seal driver and protective cone.



### **"CAUTION"**

**When installing bearing (6) use care to prevent damaging or distorting retaining ring (7).**

3. Apply lubricating fluid to the inside of the shaft seal (9) and install the shaft assembly (5, 6, 7 & 8) in the mounting flange (11).
4. Install retaining ring (4) in the flange (11) and against bearing (6) to hold the shaft assembly in place. Make certain retaining ring is fully seated in the groove.
5. Install seal (10) on pilot of flange (11).

### **Cartridge & Housing**

1. Place the housing (2) on a clean surface with the open end up and install the unitized cartridge assembly (3) in the housing. Make certain that Driv-Lok pin (3b) enters the drilled hole in the housing.
2. Install the seals (3n, 3p and ring 3q) on the cartridge.
3. Install the mounting flange and shaft assembly by inserting the shaft down through the cartridge. Rotate the shaft to pass through the rotor and to enter into the bearing in the rear port plate.
4. Position the inlet port of the housing and the outlet port of the mounting flange in the required position by turning the mounting cap and shaft assembly.
5. Install the four screws (1) and torque to 135 ft./lbs.

### **UNITIZED PUMPING CARTRIDGE (Figures V & VII)**

### **DISASSEMBLY**

1. Remove the four screws (3a) and lockwashers (3c) from the rear port plate (3d). The Driv-Lok pin (3b) and the bearing in the rear port plate (3d) are pressed into the port plate and should not be removed unless damaged and replacement parts are required.
2. Remove dowel pin (3e), cam ring (3f) and dowel pin (3k).
3. Remove the Vanes (3h), and the pins (3j) from the rotor (3g).
4. Remove the seals (3n, 3p and back-up ring 3q) from the pressure plate (3m).

Wash all the metal parts in cleaning solvent and dry thoroughly. Discard the rubber seals.

Place all the parts on a clean lint free surface and inspect for wear marks, nicks and burrs. Light scoring on the wear surfaces of the port plates may be removed by lapping. The vanes must move freely in the rotor slots and not bind or have excessive play. The edge of the vanes and the rotor slots may be stoned with a fine India stone to remove all burrs. Inspect the cam ring for excessive wear (ripples or washboard marks on the contour). Replace a badly worn or defective cam ring.

All metal parts that have been lapped or stoned must be washed again in cleaning solvent and dried before they are assembled.

Make certain that all internal passages in the port plates, rotor, vanes and vane pins are open and clean.

### **REASSEMBLY**

The Model C T5D and T5SD cartridge assembly is available for either left hand (CCW) or right hand (CW) rotation, (e.g. T5D-028-L or T5D-028-R). The left hand port plate (3d & 3m) cannot be used in the right hand pumps and right hand plates (3d & 3m) cannot be used in the left hand model. See figures IV & V. All other cartridge parts are interchangeable.

1. Place pressure plate (3m) on a clean bench with the wear face up and apply clean hydraulic fluid to the face.
2. Install dowel pin (3k) in the pressure plate.
3. Center the rotor (3g) on the pressure plate with the splined side of the rotor up.
4. Insert one vane pin (3j) in each vane slot in the rotor. The pins must move freely and be inserted against the bottom of the hole.

### **CAUTION**

The vanes must be installed properly for the pump to function. Examine the vanes very closely and notice the precision finish on the bottom of the vane and that the two holes on the bottom are smaller than the holes on top of the vanes.

5. Install the vanes (3h) in the rotor with the bottom of the vane toward the center of the rotor and the leading edge in the direction of rotation.

### **NOTE**

The two holes are on the side of the trailing edge of the vane.

6. Install the cam ring (3f) over the dowel pin (3k) with the arrow pointing in the direction that the pump is intended to run.

### NOTE

The arrow on the cam ring must indicate the same direction as the stamped arrow on the pressure plate, also the leading edge of the vane must be in the correct position.

7. Install dowel pin (3e) in cam ring.

If Driv-Lok pin (3b) or bearing was removed from

the rear port plate (3d), it must be replaced.

8. Install the Driv-Lok pin (3b) into the back of the rear port plate (3d). (Grooved end first.)
9. Pour hydraulic fluid over the cam ring and rotor and install the rear port plate (3d) over the dowel pin (3e).
10. Install the four screws (3a) and lockwashers (3c) through the rear port plate (3d), cam ring (3f) and into the front port plate (3m) and tighten with a screw driver. Install seals (3n, 3p and ring 3q) on the front port plate.

## MODEL NO. KEY — SERIES T5D T5\*D — 045 — 1R00 — C1 — \*\* Special Modification

Vane pump series. Insert an "S" at the asterisk (\*) for the severe duty pump.

Cartridge size — (gpm at 1200 rpm reference)

Code	gpm	L/min	Code	gpm	L/min
028	28	106	038	38	144
031	31	117	042	42	159
035	35	132	045	45	170

### Shaft

1. Keyed — SAE — C
2. Keyed Non SAE
3. Splined SAE-C
4. Splined Non SAE

### Fluid Class

1. Compatible with Buna N
5. Compatible with Viton

Design letter — Subject to change by mfr.

### Porting Combination

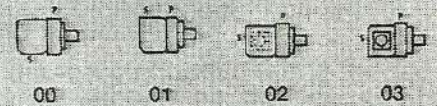

Pump Rotation (viewed from shaft end)  
R: CW, L: CCW

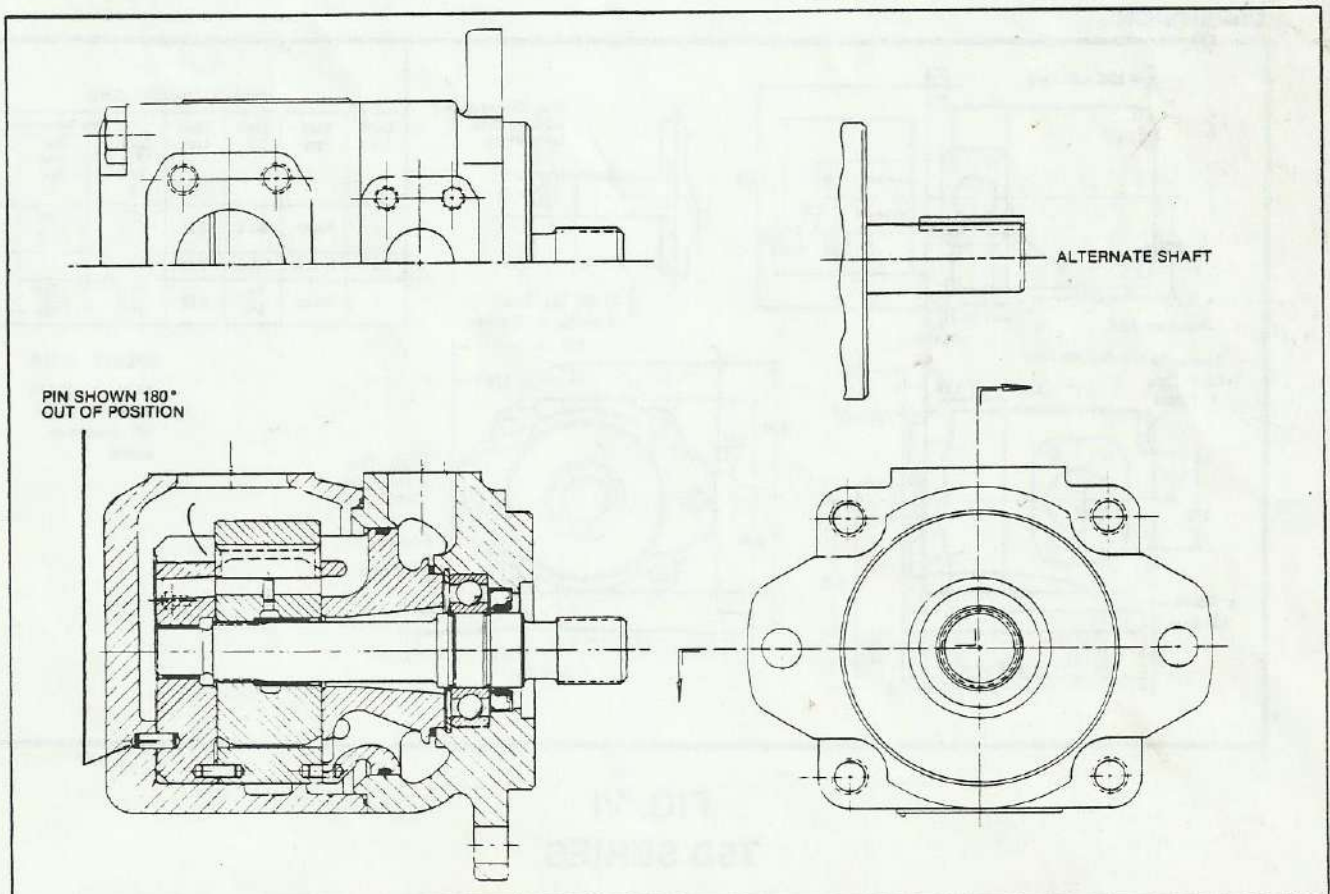

CROSS SECTION VIEW — T5D SERIES

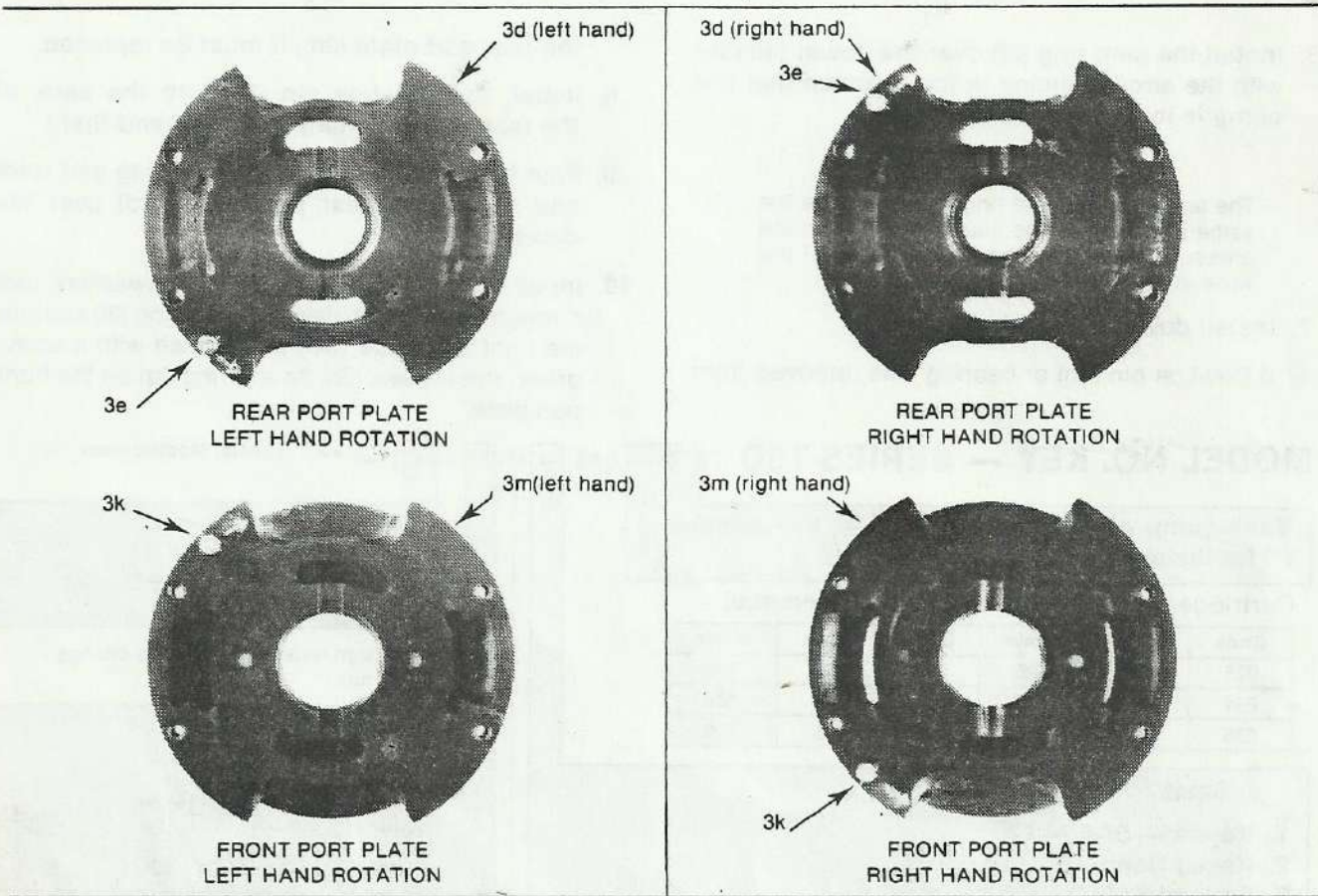

PUMP SHAFT ROTATION AS VIEWED FROM  
SHAFT END OF PUMP

FIG. V

**DIMENSIONS**

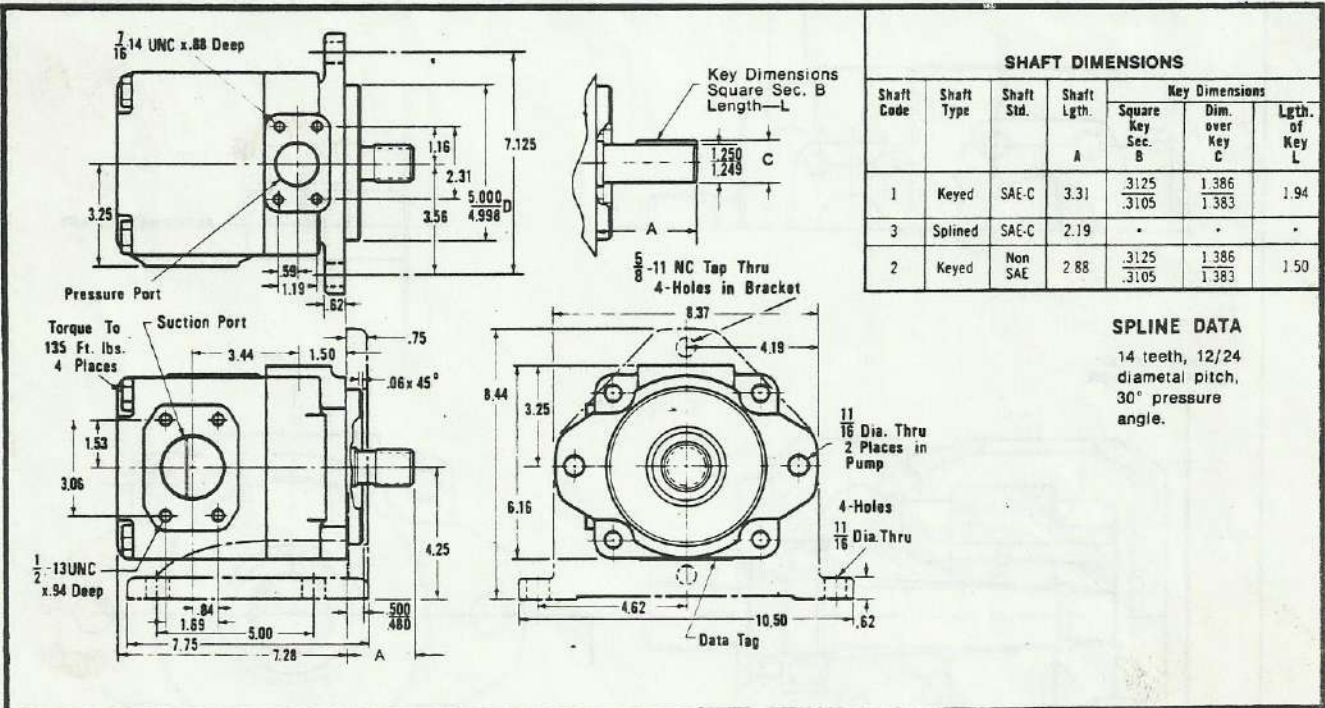

SHAFT DIMENSIONS						
Shaft Code	Shaft Type	Shaft Std.	Shaft Lgth.	Key Dimensions		
				Square Key Sec. B	Dim. over Key C	Lgth. of Key L
1	Keyed	SAE-C	3.31	.3125 .3105	1.386 1.383	1.94
3	Splined	SAE-C	2.19	-	-	-
2	Keyed	Non SAE	2.88	.3125 .3105	1.386 1.383	1.50

**SPLINE DATA**  
14 teeth, 12/24  
diametal pitch,  
30° pressure  
angle.

FIG. VI  
T5D SERIES

## T5D & T5SD UNITIZED CARTRIDGE PARTS LIST

ITEM 3 UNITIZED CARTRIDGE ASSY. FOR T5D*		These parts and common parts listed below are a complete T5D Unitized Cartridge Assembly				
Model No.	Code No.	3d Rear Port Plate Ass'y	3f Cam Ring	3m Front Port Plate	3n Seal	3p Seal
Right Hand or CW Rot.		S14-26824	034-49933 034-48532 034-48533 034-48534 034-48535 034-48536 034-48537	034-72328	691-10244	691-10232
T5D-024-R	S14-28698					
T5D-028-R	S14-53688					
T5D-031-R	S14-53690					
T5D-035-R	S14-53692					
T5D-038-R	S14-53694					
T5D-042-R	S14-53696					
T5D-045-R	S14-53698					
Left Hand or CCW Rot.		S14-26825	034-49933 034-48532 034-48533 034-48534 034-48535 034-48536 034-48537	034-72237	691-10244	691-10232
T5D-024-L	S14-25522					
T5D-028-L	S14-53689					
T5D-031-L	S14-53691					
T5D-035-L	S14-53693					
T5D-038-L	S14-53695					
T5D-042-L	S14-46215					
T5D-045-L	S14-53699					
QTY.	1	1	1	1	1	1

ITEM 3 UNITIZED CARTRIDGE ASSY. FOR T5SD**		These parts and common parts listed below are a complete T5SD Unitized Cartridge Assembly				
Model No.	Code No.***	3d Rear Port Plate Ass'y	3f Cam Ring	3m Front Port Plate	3n Seal	3p Seal
Right Hand or CW Rot.		S14-53713	034-59294 034-70747 034-70748 034-70749 034-70750 034-70751 034-70752	034-72328	691-10244***	691-10232***
T5SD-024-R	S24-10278					
T5SD-028-R	S14-53700					
T5SD-031-R	S14-53702					
T5SD-035-R	S14-53704					
T5SD-038-R	S14-53706					
T5SD-042-R	S14-53708					
* T5SD-045-R	S14-53710					
Left Hand or CCW Rot.		S14-53697	034-59294 034-70747 034-70748 034-70749 034-70750 034-70751 034-70752	034-72237	691-10244***	691-10232***
T5SD-024-L	S24-10279					
T5SD-028-L	S14-53701					
T5SD-031-L	S14-53703					
T5SD-035-L	S14-53705					
T5SD-038-L	S14-53707					
T5SD-042-L	S14-53709					
T5SD-045-L	S14-53711					
QTY.	1	1	1	1	1	1

\*For use with petroleum base fluids.

\*\*For severe duty applications.

\*\*\* When using fluid requiring Viton A seals add -5 to code no. and specify 695-20244 and 695-20232 seals.

### COMMON UNITIZED CARTRIDGE PARTS FOR ALL MODELS

Item	Qty	Part No.	Description	Item	Qty	Part No.	Description
3a	4	317-10320	10-24 x 3 Fillister Hd. Screw	3g	1	S14-22869	Rotor Assy.
3b	1	323-82004	¼ x ¾ Driv-Lok Pin	3h	10	034-72190	Vanes
3c	4	348-10010	Lockwasher	3j	10	034-24984	Vane Pins
3e	1	324-21612	¼ x ¾ Dowel Pin	3k	1	324-21612	¼ x ¾ Dowel Pin
				3q	1	618-15017	Back-up Ring

## T5D — T5SD PARTS LIST

ITEM	PART NO.	DESCRIPTION	QUANTITY
1	306-40157	Hex head cap screw $\frac{5}{8}$ - 11 x $5\frac{1}{2}$	4
2	034-47917	Housing	1
3	See page 13	Pumping cartridge & seals	1
4	356-32283	Internal snap ring 5008-283	1
5	034-70853	External retaining ring	1
6	230-00207	Ball bearing	1
7	034-70853	External retaining ring	1
8	034-70859	Splined shaft SAE-C (#3) (Standard)	1
	034-70858	Keyed shaft SAE-C (#1) (Standard)	1
	034-70923	Splined shaft not SAE (#4) (Optional)	
	034-70980	Keyed shaft not SAE (#2) (Optional)	1
	034-46754	Key (use with #034-70858 shaft)	1
	034-49676	Key (use with #034-70980 shaft)	1
9	*620-82062 (s)	Shaft seal	1
	**620-82066 (s)	Shaft seal	1
10	*671-10159 (s)	Square section seal	1
	**695-10159 (s)	Square section seal	1
11	034-47916	Mounting flange	1
(s)	*S14-20047	Seal kit (includes cartridge seals)	1
(s)	**S14-20047-5	Seal kit (includes cartridge seals) for T5SD	1
	S14-20085	#3 shaft assembly (#5, 6, 7 & 8) (Standard)	1
	S14-20084	#1 shaft assembly (#5, 6, 7 & 8) (Standard)	1
	S14-40835	#4 shaft assembly (#5, 6, 7 & 8) (Optional)	1
	S14-25646	#2 shaft assembly (#5, 6, 7 & 8) (Optional)	1

\*For use with petroleum base fluids and severe duty applications.

\*\*For use with fluids requiring Viton A seals.

Foot mounting bracket kit (optional): Code No. S14-08057  
(includes 1 Pt. No. 034-24342 bracket and 2 screws ( $\frac{5}{8}$ -11 x  $1\frac{1}{4}$ ))

\*\*\*Add -5 to the end of model and code no. when ordering a kit requiring Viton A seals. Change seal prefix to 675 or 695 when ordering seal separately.

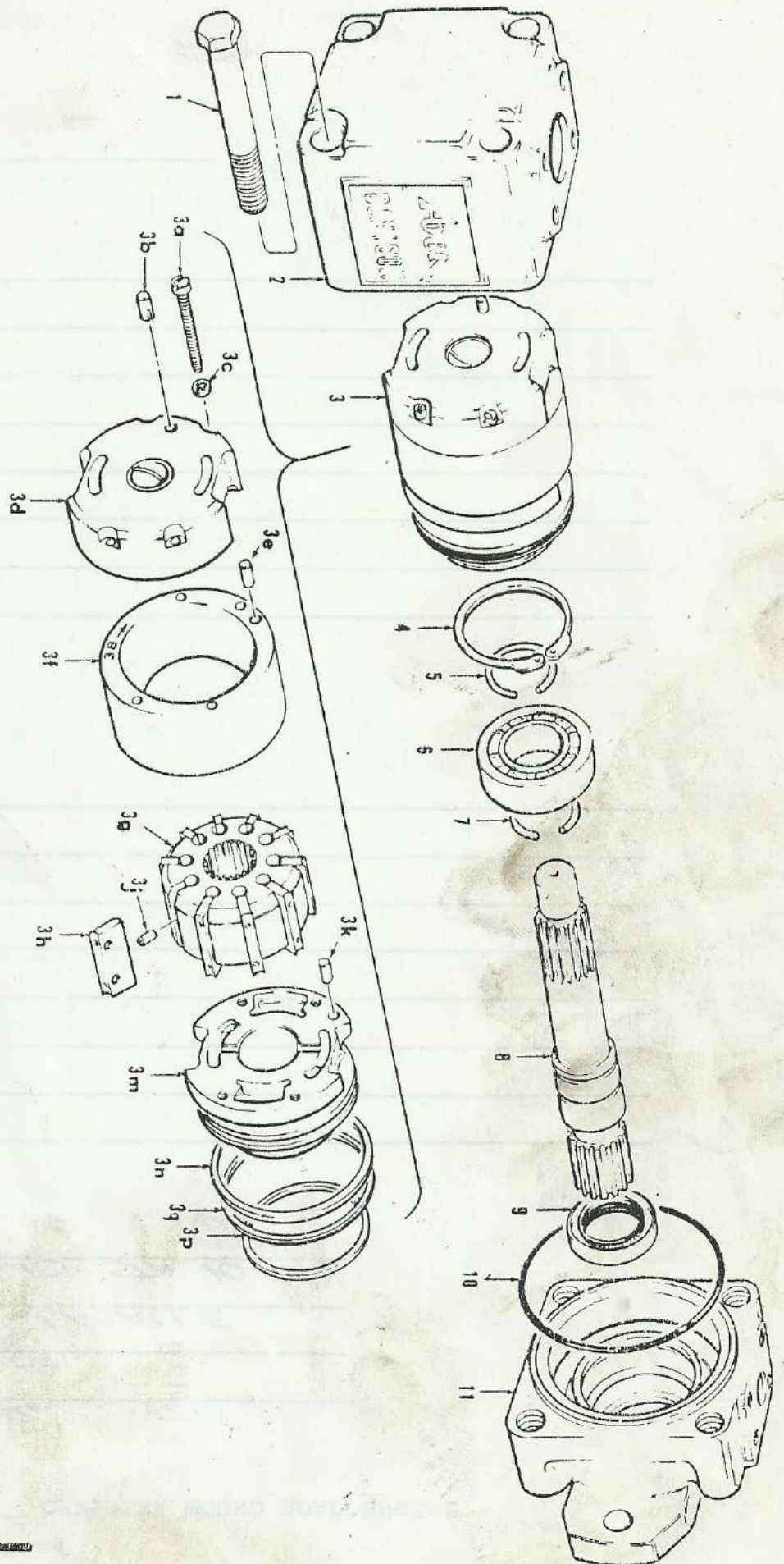

CARTRIDGE ILLUSTRATED FOR  
 CCW (left hand) Rotation

**FIG. VII**