

**VICKERS**

# Service Parts Information

Pressure  
Compensated  
Medium Pressure  
6 GPM Inline  
Piston Pumps

PVB6A-(F)RS-20-CA-11

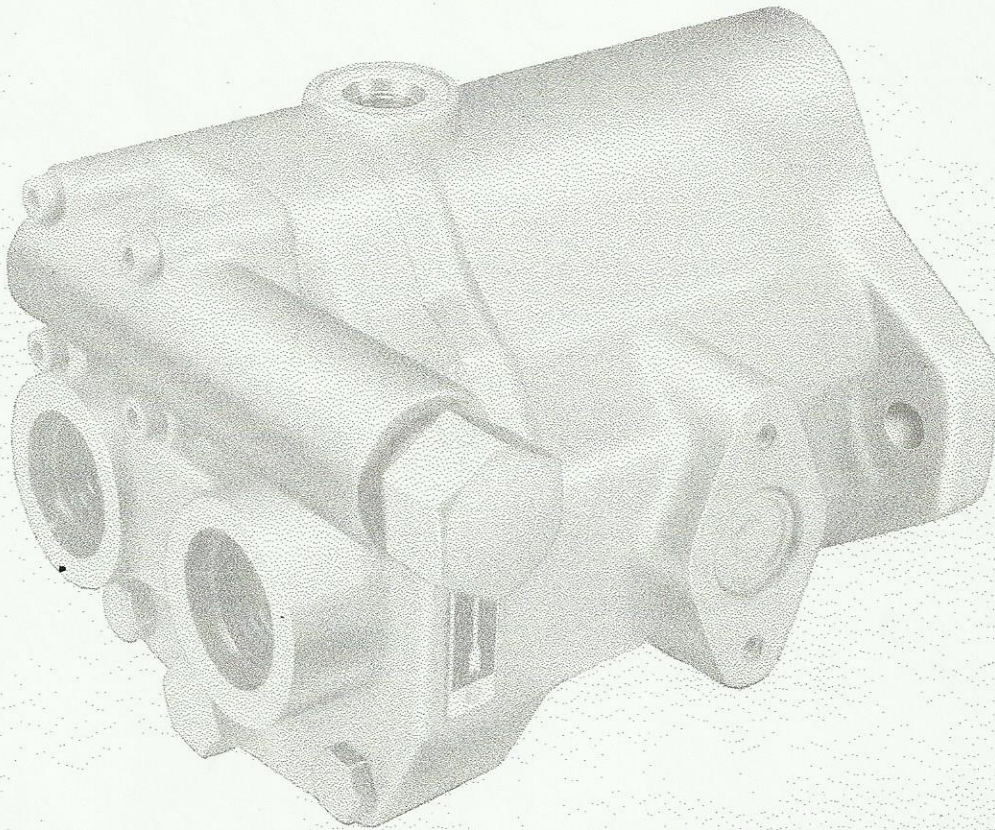

Vickers, Incorporated

1401 Crooks Road  
Troy, Michigan 48084

Revised 9-1-85

I-3281-S

*A Libbey-Owens-Ford Company*

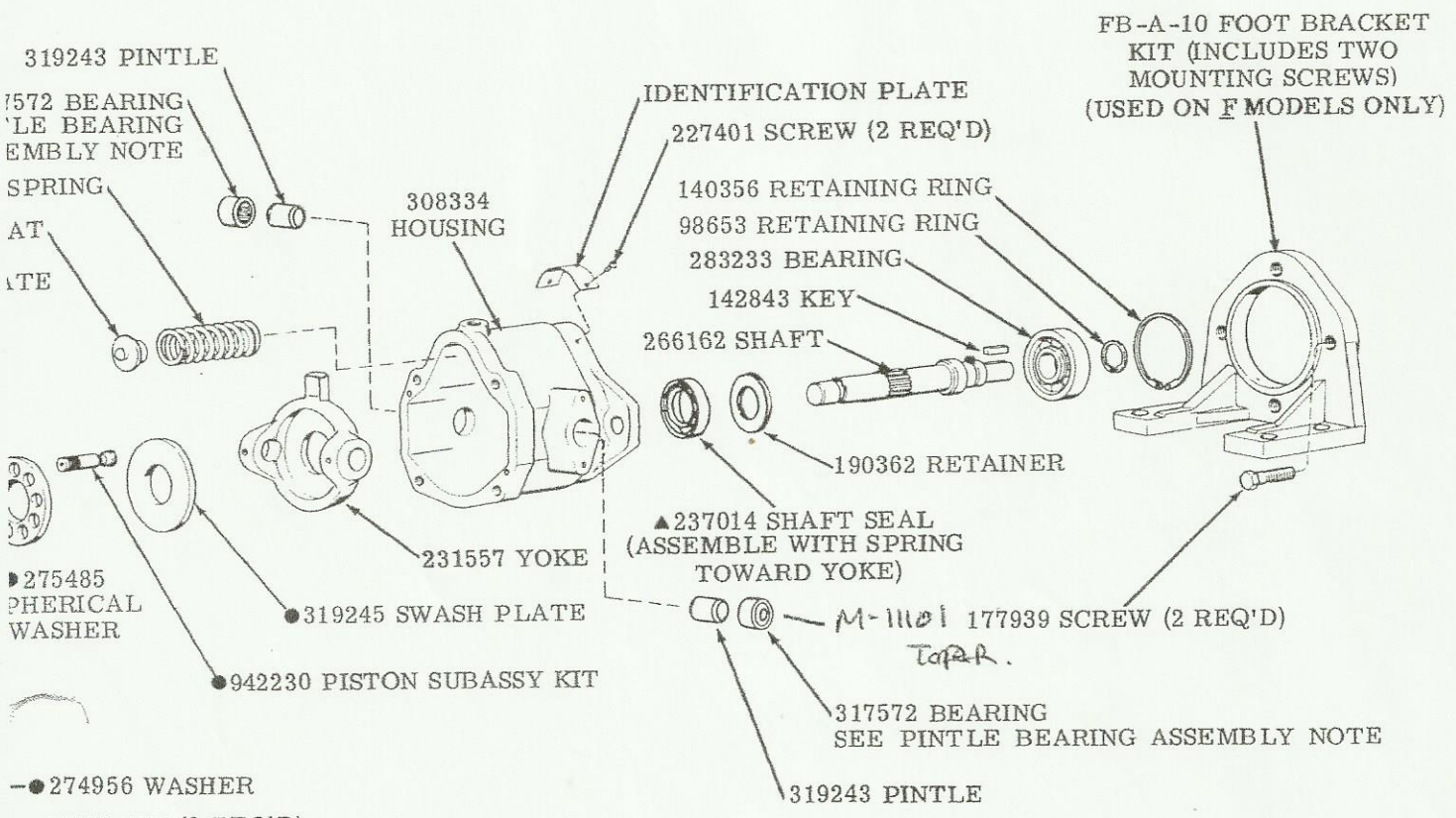

⊖ CAUTION  
POSITION GASKET WITH SMALL END  
OF TEARDROP HOLE POINTING IN  
DIRECTION OF COMPENSATOR ADJ-  
USTING PLUG.

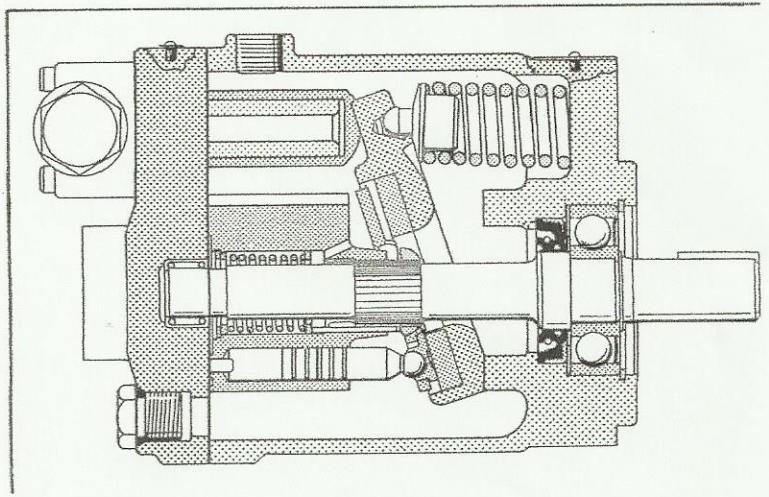

PRESS BEARING FLUSH  
WITH INSIDE SURFACE  
OF HOUSING

317572  
BEARING  
(REF.)

YOKE

319243 PINTLE  
(REF.)

HOUSING

**PINTLE BEARING ASSEMBLY NOTE**  
MAKE CERTAIN THE BEARING O. D. SURFACE  
AND THE MATING SURFACE IN THE HOUSING  
IS CLEAN. APPLY SEALING COMPOUND  
(LOCTITE A (10-1) OR EQUIVALENT) TO THE  
BEARING O. D. AND PRESS IN PLACE.

**CAUTION**

DO NOT ALLOW SEALING COMPOUND  
TO CONTACT THE BEARING NEEDLES.

SEE

37:

37313

MODEL	VALVE PLATE S/A
PVB6A-(F)RS	942223

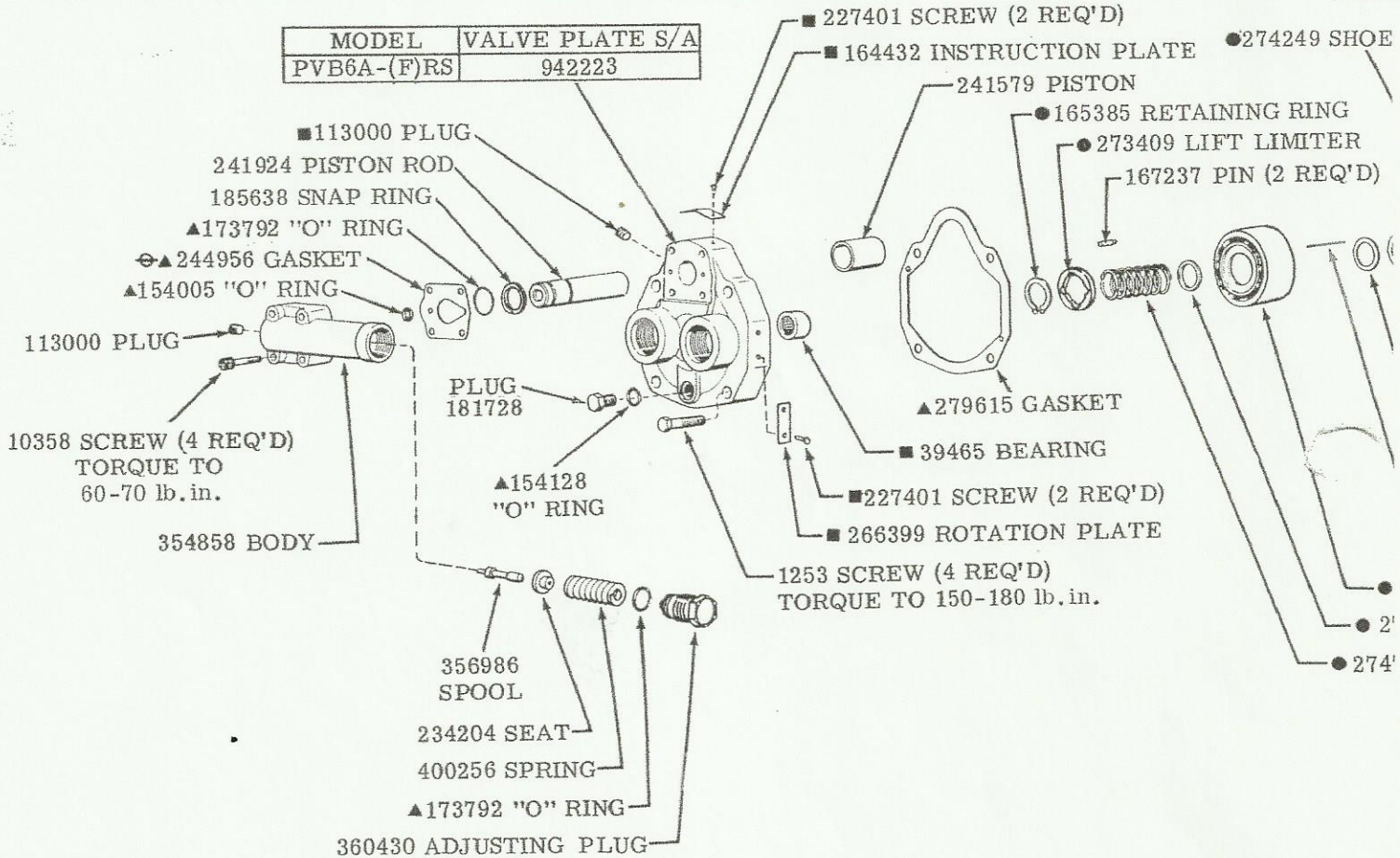

● INCLUDED IN 938264  
ROTATING GROUP

■ INCLUDED IN  
VALVE PLATE S/A

▲ INCLUDED IN  
919508 SEAL KIT

**WARNING: USE THIS DRAWING FOR PARTS INFORMATION ONLY. SEE OVERHAU**

## MODEL CODE BREAKDOWN

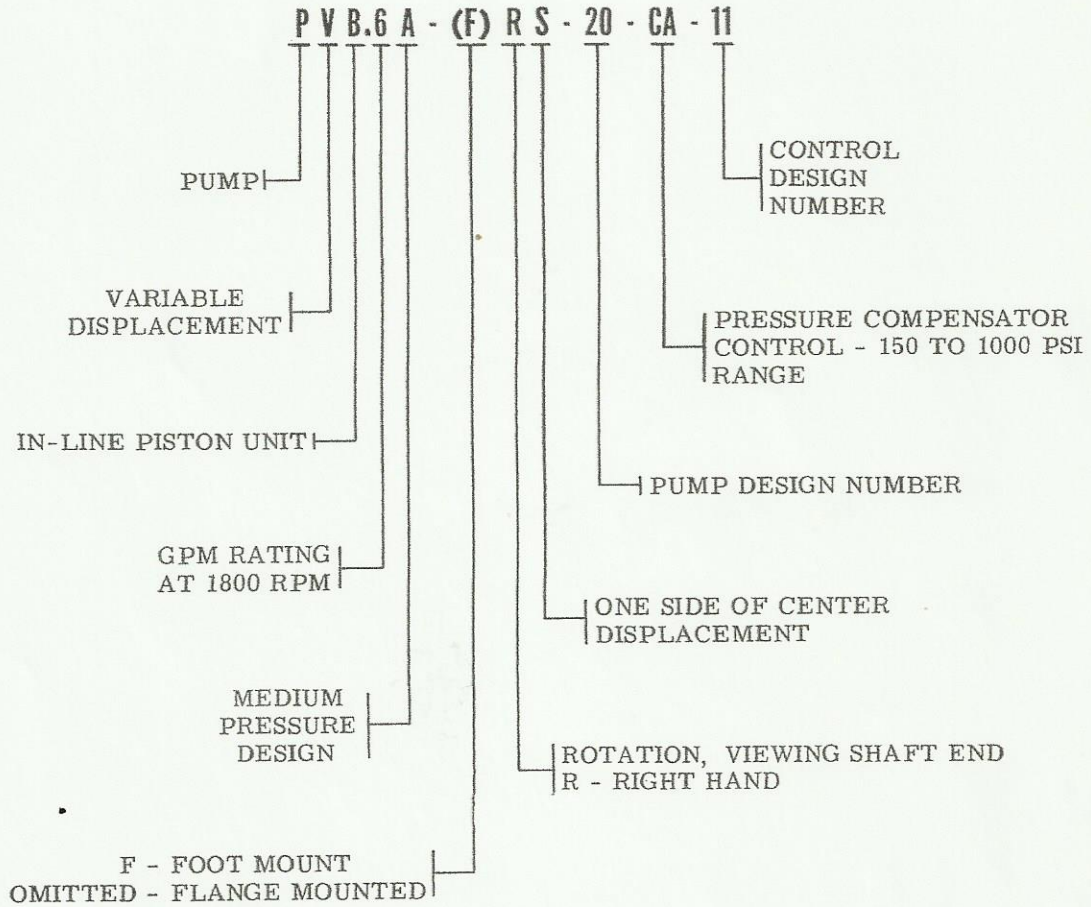

For satisfactory service life of these components in industrial applications, use full flow filtration to provide fluid which meets ISO cleanliness code 16/13 or cleaner. Selections from Vickers OFP, OFR, and OFRS series are recommended.