

Service Parts Information

Variable In-Line
Piston Units

PVB10-(F)**(Y)-30/31-*(*) (L)-1*

PVB15-(F)**(Y)-30/31-*(*) (L)-1*

MPVB10-(F)VD(Y)-30/31-* -10

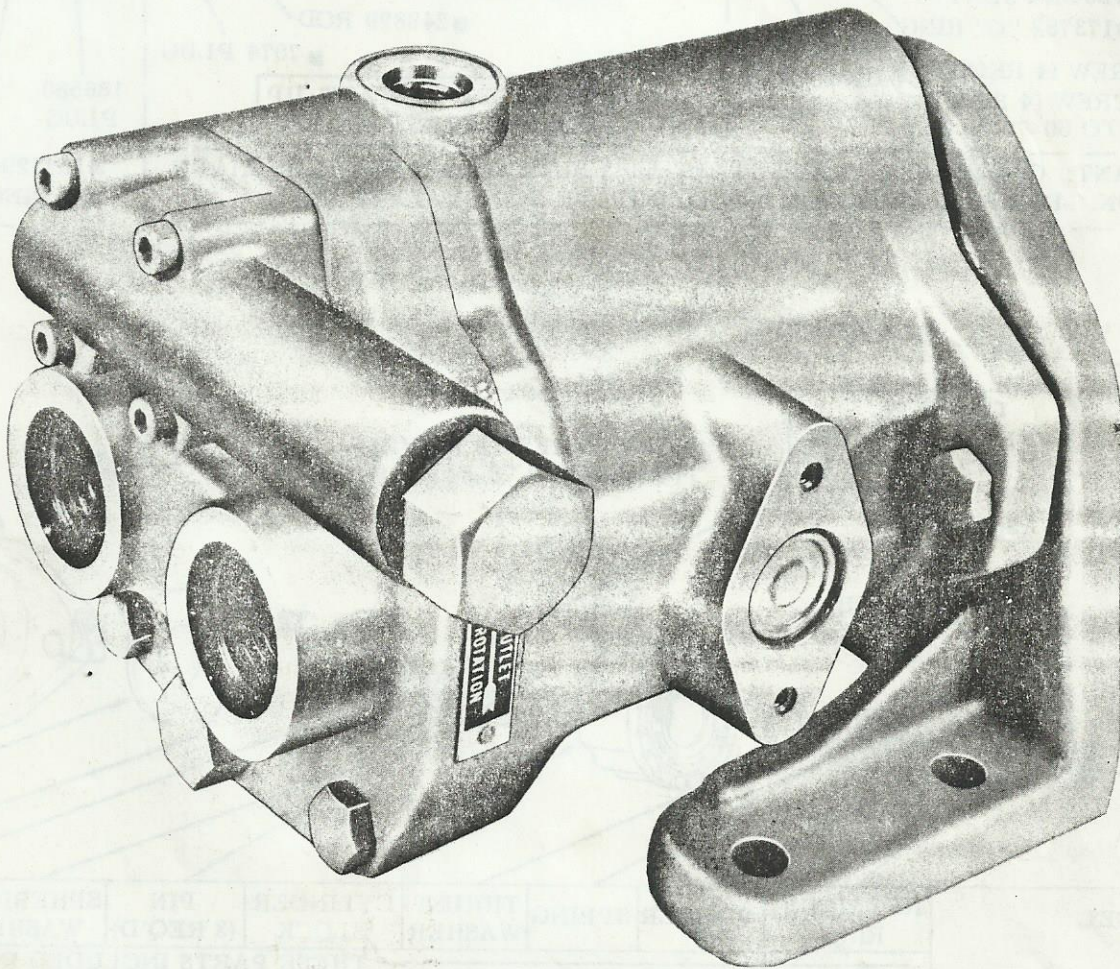

Vickers, Incorporated

P.O. Box 302
Troy, Michigan 48007-0302

Revised 12-1-87

I-3268-S

NOTE
COMPENSATOR S/A PARTS
SHOWN WITHIN THIS AREA.

| PRESSURE RANGE (PSI) | COMPEN-SATOR SUBASSY | SPRING |
|------------------------------------|----------------------|----------|
| (C) 350-3000 (10) 350-2000 (15) | 942158 | 239371 |
| (CM) 350-1500 | 942159 | ● 265693 |

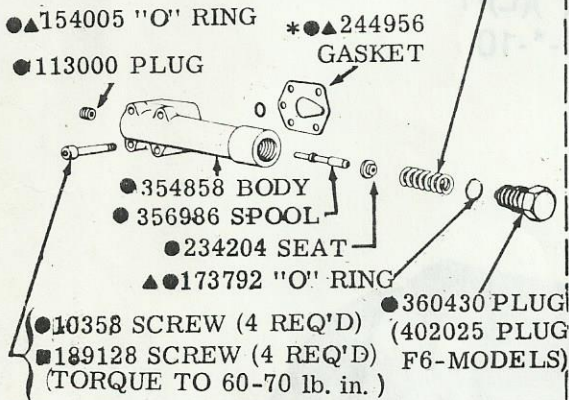

■ INCLUDED IN START-UP VALVE (E) SUBASSY 942157

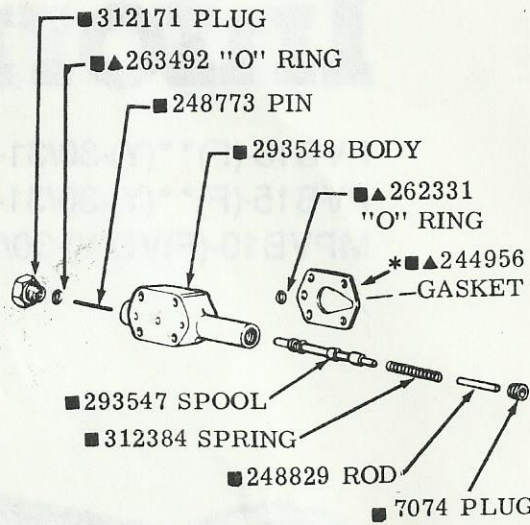

■ INCLUDED IN START-UP VALVE SUBASSY 942157.

1276 SCREW (4 REQ'D)
(TORQUE TO 25-35 lb. ft.)

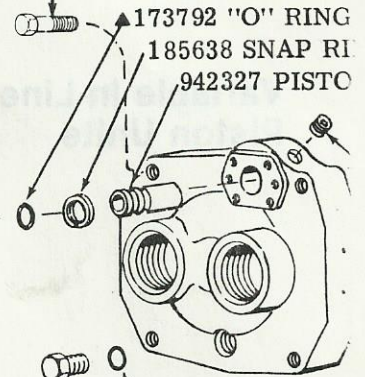

| YOKE | HOUSING |
|--------|---------|
| 325689 | 3083 |
| 342743 | 3576 |
| 325689 | 3083 |
| 342743 | 3987 |

IMPORTANT: COMPENSATOR AND START-UP VALVE SHOWN FOR L. H. SHAFT ROTATION. FOR R. H. ROTATION UNITS, ROTATE BOTH VALVES 180°.

CAUTION
DO NOT USE BACK-UP WASHER WITH NEW SPHERICAL WASHER.

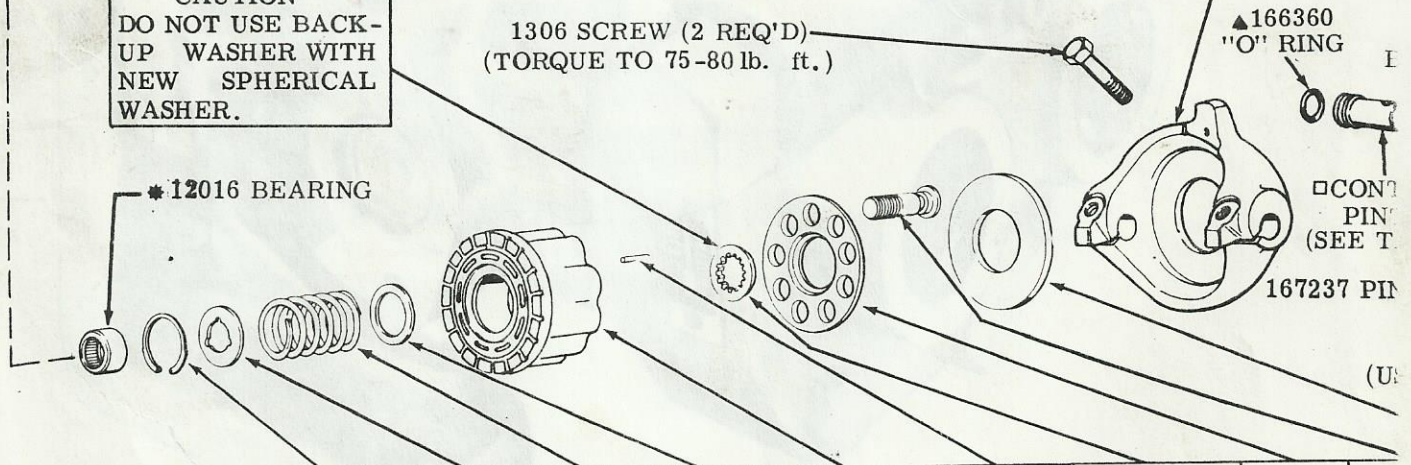

| MODEL | RETAINING RING | WASHER | SPRING | THRUST WASHER | CYLINDER BLOCK | PIN (3 REQ'D) | SPHERICAL WASHER | SHOE PLATE | PIS S/A | |
|-------------------------|----------------|--------|--------|---------------|----------------|---------------|------------------|------------|---------|--|
| PVB10-**(Y)-3*-**-1* | 93509 | 245223 | 247294 | 241954 | 321703 | 248812 | 423324 | 275961 | 94 | |
| MVB10-**(Y)-3*-**-1* | | | 403858 | | 260860 | | | | 94 | |
| PVB15-**(Y)-3*-**-1* | | | | | | | | | | |
| F6-PVB15-**(Y)-3*-**-1* | | | | | | | | | | |

● PARTS INCLUDED IN COMPENSATOR S/A.

NOTE: TYPE 'C' & 'CM' COMPENSATOR CONTROL PARTS SHOWN. SEE BACK PAGE FOR MANUAL CONTROLS. REFER TO PARTS DRAWING I-3243-S FOR 'CVP' PRESSURE LIMITING & LOAD SENSING COMPENSATOR CONTROL.

| MODELS | PINTLES | |
|-------------|---------|--------|
| | CONTROL | OTHER |
| HANDWHEEL | 269657 | |
| LEVER | 269658 | 265425 |
| COMPENSATOR | 265425 | |

INCLUDED IN
VALVE PLATE S/A

| MODEL | *INCLUDED IN VALVE PLATE SUBASSY |
|---------------------------|----------------------------------|
| PVB10-RD(Y)-3*-H/M-10 | 942160 |
| PVB10-LD(Y)-3*-H/M-10 | 942161 |
| MVB10-UD(Y)-3*-H/M-10 | 942162 |
| PVB15-RD(Y)-3*-H/M-10 | 942163 |
| PVB15-LD(Y)-3*-H/M-10 | 942164 |
| PVB10-RS(Y)-3*-C(*)-11 | 942165 |
| PVB10-LS(Y)-3*-C(*)-11 | 942166 |
| F6-PVB15-RS(Y)-3*-C(*)-11 | 942167 |
| F6-PVB15-LS(Y)-3*-C(*)-11 | 942168 |

***NOTE**
POSITION COMPENSATOR GASKET WITH SMALL END OF TEARDROP HOLE POINTING IN DIRECTION OF COMPENSATOR ADJUSTING PLUG.

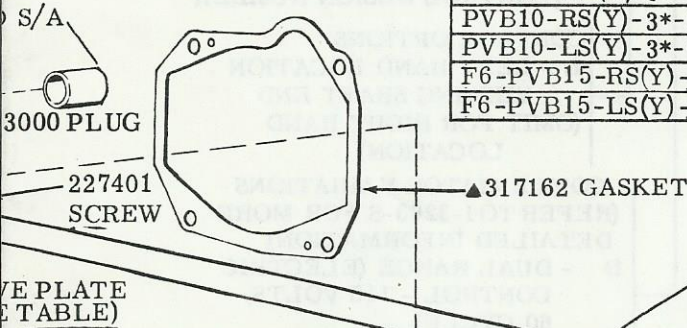

ROTATION PLATE SHOWN FOR RIGHT HAND (CW) SHAFT ROTATION. LOCATE ON OPPOSITE SIDE OF VALVE PLATE FOR LEFT HAND (CCW) ROTATION.

▲INCLUDED IN 919682 SEAL KIT

F3 EQUIVALENT SEAL KIT 919686

| MODEL | SCREW | ROTATION PLATE |
|--------------------------|--------|----------------|
| VB1*-D(Y)-3*-H/M-10 | 227401 | 195060 |
| VB1*-S(Y)-3*C(*)/CM-11 | 227407 | 404751 |
| VB10-D(Y)-3*-H/M-10 | | |
| F6-PVB15-S(Y)-3*-C(*)-11 | 227407 | 404751 |

FOOT BRACKET KIT FB-B-10
(USED ON *VB*-(F) MODELS ONLY)
(INCLUDES SCREWS)

| MODEL | SHAFT | KEY |
|--------------|--------|-------|
| *VB*-***-3* | 261478 | 22971 |
| *VB*-***Y-3* | 270369 | 58303 |

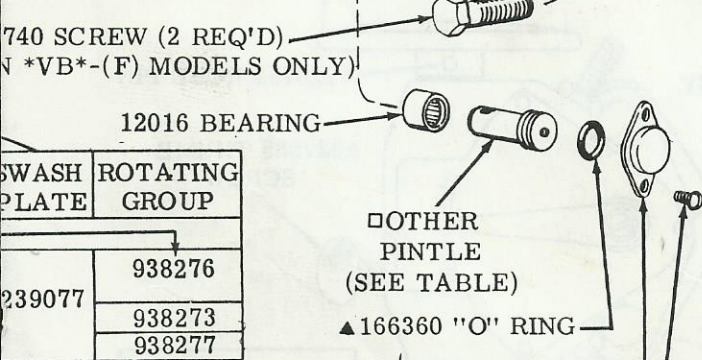
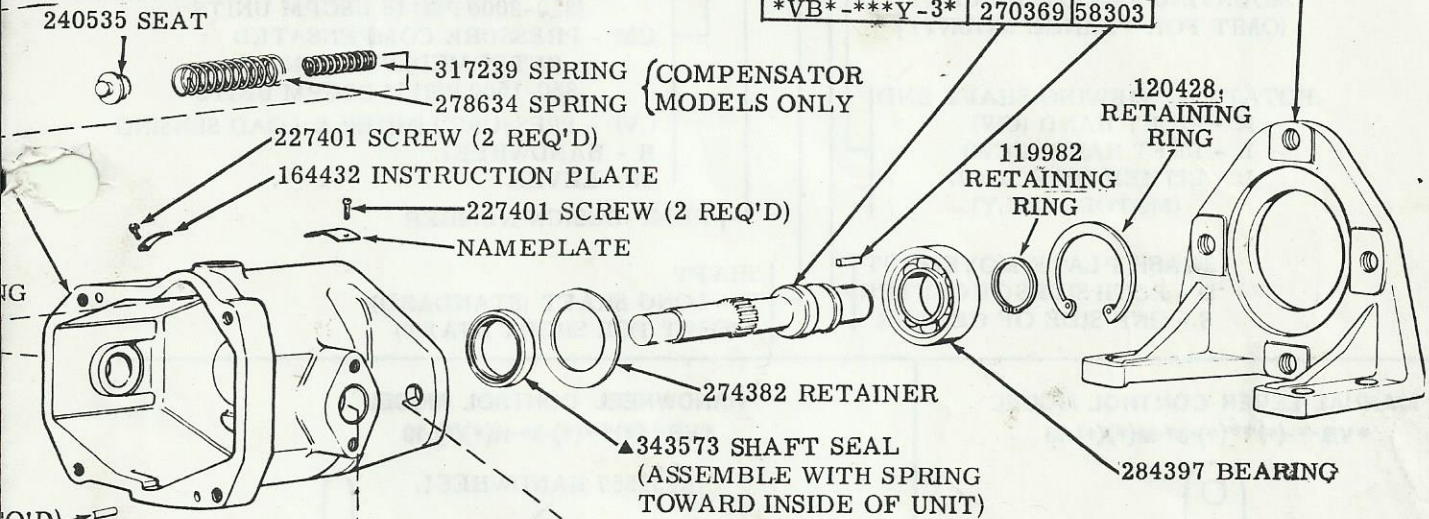

| WASH PLATE | ROTATING GROUP |
|------------|----------------|
| | 938276 |
| 239077 | 938273 |
| | 938277 |

USED ON HAND-WHEEL AND LEVER MODELS ONLY

F6 MODEL SHAFT SEAL ARRANGEMENT
(REPLACES SEAL, RETAINER, AND BEARING SHOWN ABOVE.)

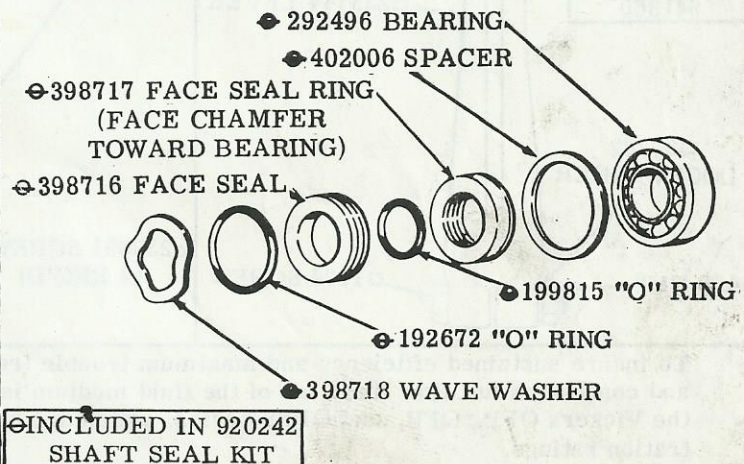

INCLUDED IN 920242 SHAFT SEAL KIT

MODEL CODE BREAKDOWN

(F3/F6)-*VB*(-)**(*)-3*-*(*)-(L)-1*

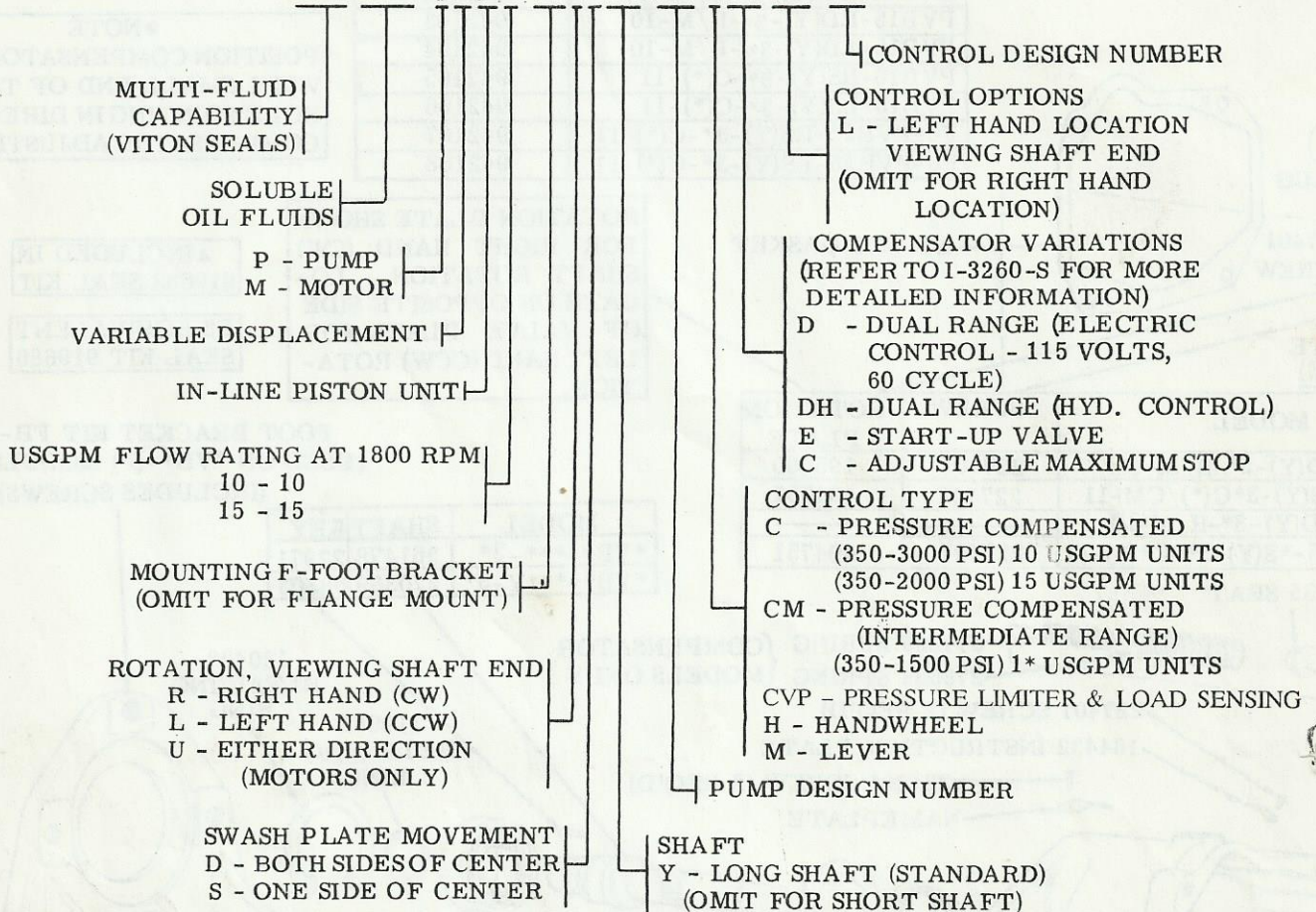

MANUAL LEVER CONTROL MODEL

VB(-)**(*)-3*-M(*)-(*)-10

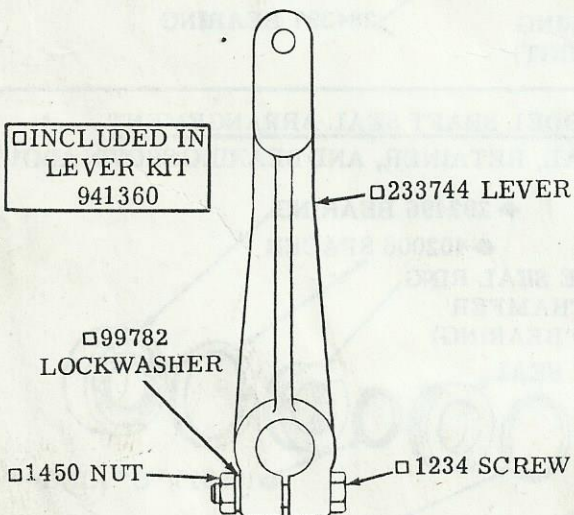

HANDWHEEL CONTROL MODEL

VB(-)**(*)-3*-H(*)-(*)-10

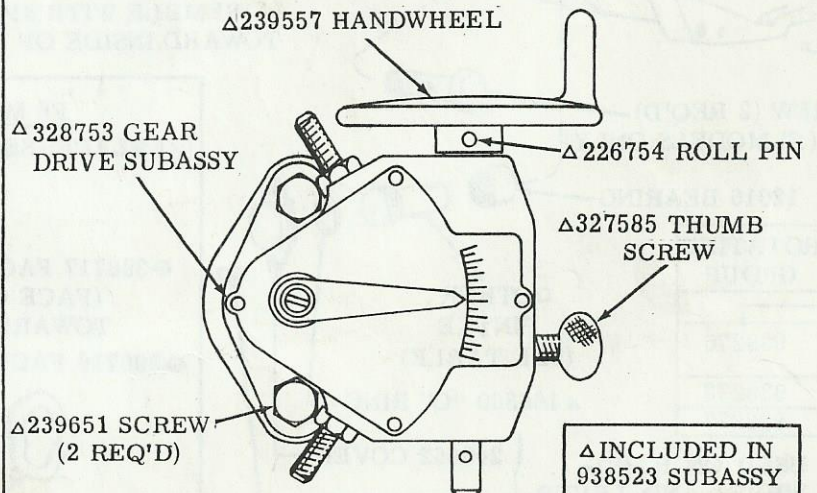

To insure sustained efficiency and maximum trouble free life of this precision equipment, initial and continuous full flow filtration of the fluid medium is essential. Select and apply filters from the Vickers OFP, OFR, and OFRS series, which are available in 3, 10, and 25 micrometre filtration ratings.