

Abex

DENISON

SERVICE LITERATURE

VANE TYPE FLUID MOTOR - MODEL M1D & M1D1

INSTALLATION, OPERATION AND OVERHAUL INSTRUCTIONS

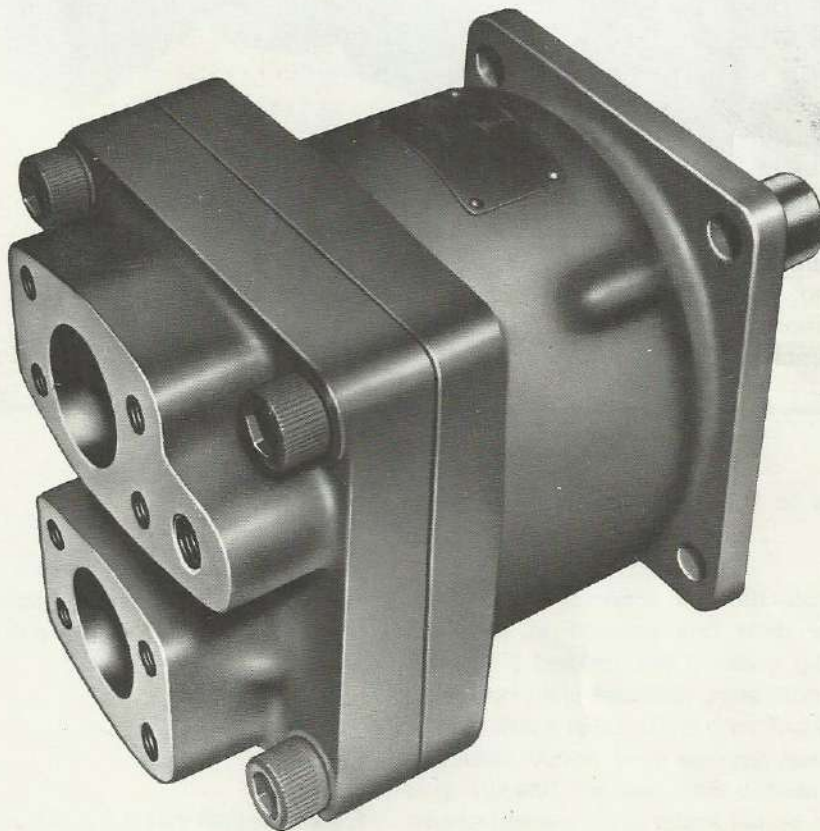

Vane Type Fluid Motor-Model M1D & M1D1

Table of Contents

Section I	INTRODUCTION AND DESCRIPTION	3
Section II	INSTALLATION	
	Mounting	4
	Piping	4
	Oil	
Section III	OPERATION	5
Section IV	MAINTENANCE	
	General	5
	Troubleshooting	6
Section V	OVERHAUL	
	General	7
	Special Tools	7
	Disassembly	8
	Cleaning, Inspection and Repair	8
	Lubrication	8
	Reassembly	9

Section I INTRODUCTION AND DESCRIPTION

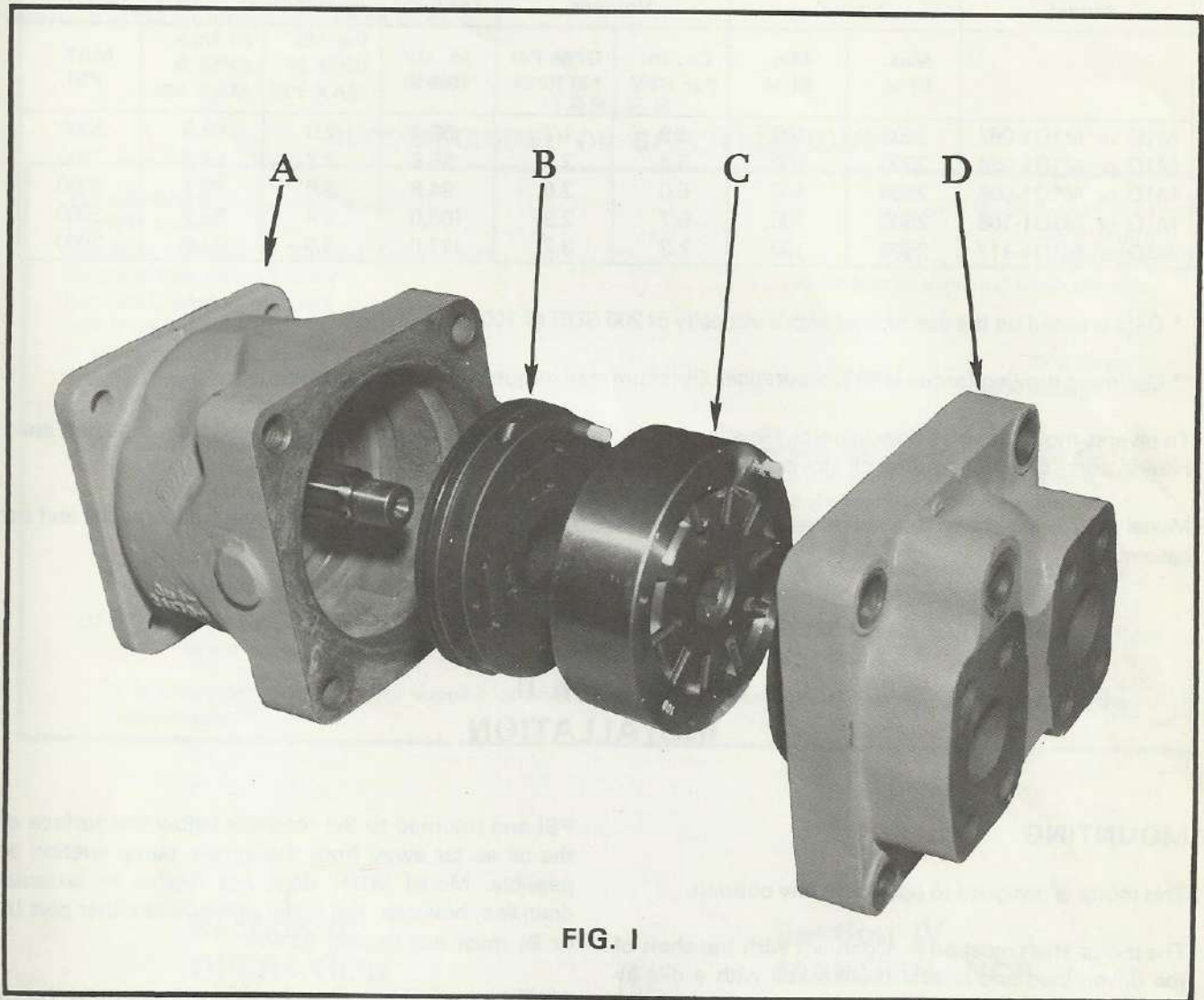

FIG. 1

GENERAL

This manual contains installation, operating maintenance and overhaul instructions for Abex/Denison M1D and M1D1 series fluid motor.

DESCRIPTION

The fixed displacement motor is a rotary balanced vane type motor converting hydraulic forces into rotary mechanical motion. To determine the maximum

operating pressure and speed of any model, refer to Table I.

The motor consists of four basic sub-assemblies; (A) body or housing and shaft with a permanently lubricated bearing and a rotary type shaft seal; (B) a front port plate assembly consisting of port plate with a built in check valve; (C) a cam ring assembly containing the rotor, vanes, vane springs, spring guides and cam ring; (D) end cap assembly consisting of end cap and needle bearing. Two check valves are contained in the end cap assembly for model M1D1 which is internally drained.

**TABLE I
PERFORMANCE DATA
THEORETICAL OPERATING CHARACTERISTICS***

Model	Speed		Volume		Torque**	Horsepower Output		Pressure
	Max. RPM	Min. RPM	Cu. In. Per REV.	GPM Per 100 RPM	In. Lb/ 100PSI	Per 100 RPM @ MAX PSI	At Max. RPM & MAX PSI	MAX. PSI
M1D or M1D1-062	2500	100	3.9	1.7	62.4	2.0	49.5	2000
M1D or M1D1-086	2500	100	5.4	2.3	85.9	2.7	68.2	2000
M1D or M1D1-095	2500	100	6.0	2.6	94.8	3.0	75.1	2000
M1D or M1D1-108	2500	100	6.7	2.9	108.0	3.4	85.7	2000
M1D or M1D1-117	2500	100	7.3	3.2	117.0	3.7	92.8	2000

* Data is based on the use of fluid with a viscosity of 200 SUS @ 100° F.

** Optimum running torque is 90% theoretical. Optimum stall torque is 75% theoretical.

To reverse motor, reverse flow to ports. Flow in port "A" gives clockwise rotation when viewed from the shaft end. Flow in port "B" gives counter clockwise rotation when viewed from the shaft end.

Model M1D is externally drained from the end cap. Model M1D1 is internally drained and requires a special end cap assembly.

Section II INSTALLATION

MOUNTING

This motor is designed to operate in any position.

The motor shaft must be in alignment with the shaft of the driven load and should be checked with a dial indicator. The mounting pad or adapter into which the fluid motor pilots must be concentric with the motor shaft within 0.010 TIR to prevent bearing failures. This concentricity is particularly important if the fluid motor shaft is rigidly connected to the driven load without a flexible coupling.

PIPING

Connect inlet and outlet lines to the end cap of the motor. The externally drained model must have a drain line connected to the end cap drain connection of sufficient size to prevent back pressure in excess of 50

PSI and returned to the reservoir below the surface of the oil as far away from the supply pump suction as possible. Model M1D1 does not require an external drain line, however, the outlet pressure at either port (A or B) must not exceed 50 PSI.

All fluid lines either pipe, tubing or hose must be of adequate size and strength to assure free flow through the motor. An undersize inlet line will prevent the motor from reaching full speed and will not develop sufficient torque. An undersized outlet line will create back pressure in the motor and prevent proper operation. Flexible hose lines are recommended. If rigid pipe or tubing is used, the workmanship must be accurate in order to eliminate strain on the motor end cap or the fluid connectors. Sharp bends in the lines should be eliminated whenever possible. All system piping must be cleaned with solvent or equivalent before the motor is connected. Be sure that the entire hydraulic system is free from dirt, lint, scale and other foreign material. *DO NOT USE GALVANIZED PIPE.* Galvanized coating may flake off after continued use.

NOTE:

If the circuit used will allow the motor to operate as a pump or restrict the inlet fluid availability when using the motor for dynamic braking, the inlet side of the motor must be replenished. The minimum replenishing pressure at the motor inlet should be 25 PSI.

OIL

It is recommended that a hydraulic oil be used as specified in Table II.

**TABLE II
RECOMMENDED OIL SPECIFICATIONS***

Viscosity Range	150 to 300 SUS at 100° F
Viscosity Index	90 or higher
Maximum Viscosity at Starting Temperature	4000 SUS
Minimum Operating Viscosity	70 SUS or as approved by Denison Div.
Rust and Oxidation Inhibitors	Yes
Anti-Foam Additive	Yes
API Gravity, Degrees, Range	25 through 37
Specific Gravity, 60° F/60° F, Range	0.904 through 0.840

NOTE: It is recommended, but not necessary, that the fluid contain anti-wear additive. To provide minimum noise and greater life, the hydraulic fluid selected should contain a minimum of 0.05%, by weight, of zinc and a minimum of 0.05%, by weight of phosphorous as zinc dithiophosphate or an amount of other anti-wear additive which will impart equal properties to the fluid.

Consult a Denison Division representative before using fluids which do not meet these specifications or for high temperature operation. In addition, consult him for Fire Resistant Hydraulic Fluid applications.

CAUTION: Inlet temperature of the oil for most efficient operation should be 130° F and should not exceed 150° F for vane equipment without dropping below minimum operating viscosity.

*It is suggested that the fluid supplier provide the user with certification that his product meets the requirements.

**Section III
OPERATION**

During operation, oil under pressure flows through either one of the two ports "A" or "B" in the end cap and is directed to both sides of the cam ring assembly through cast ports in the end cap and port plate assembly. The pressure applied against the vanes forces the rotor to turn and at the same time rotates the motor shaft. As the rotor turns, the oil moves to the discharge ports in the port plate and end cap (B or A). Oil entering through port "A" will force the shaft to rotate right-hand (clockwise) facing the shaft end. Oil entering through port "B" will reverse the rotation. The port plate assembly is free to move axially within the limits and is held against the cam ring assembly by a wavy washer spring until internal pressure is built up.

**Section IV
MAINTENANCE**

Since this motor is self-lubricating, preventative maintenance is limited to keeping the fluid in the system clean by changing filters frequently. Do not allow dirt to accumulate on the motor, especially around the shaft seal. Keep all fittings and screws tightened. Do not operate the motor at pressures or speeds in excess of the recommended limit.

If the motor does not operate properly, check the "Trouble Shooting Chart" in Table III before attempting an overhaul.

Overhaul is relatively simple and may be accomplished by following the procedure in Section V.

**TABLE III
TROUBLE-SHOOTING CHART**

TROUBLE	PROBABLE CAUSE	POSSIBLE REMEDY
1. External Leakage	a. Seal failure b. Defective casting	a. Replace seal b. Replace casting
2. Leakage At Fittings	a. Cracked casting b. Defective threads c. Damaged "O" Ring d. Burr	a. Replace b. Replace c. Replace d. Stone or file flat.
3. Loss In Speed Under Load	a. Low inlet pressure b. Excessive back-pressure at outlet. c. Scored port plate or end cap e. High oil temperature	a. Check Pressure b. Check pressure-increase line size. c. Relap flat to clean up. d. Use heavier oil; use oil cooler; adjust relief valve setting.
4. Poor Speed Control	a. Insufficient fluid supply b. Worn rotating group	a. Use more efficient pump. Use larger pump. Use flow control valve. b. Replace
5. Motor Fails to Start Turning	a. Insufficient torque b. Excessive motor leakage. c. Worn port plates. d. Worn rotating group e. Defective "O" ring on O.D. of front port plate. f. Insufficient pump delivery g. Motor too small	a. Increase relief valve pressure setting. b. Check flow from motor outlet if excessive, check shuttle valve in front port plate. Pressure not loading plate causing plate to move away from cam ring. c. Replace d. Replace e. Replace "O" ring if damaged. f. Pump worn or too small. g. Use larger size cam ring.
6. Shaft Play	a. Worn bearings b. Excessive side load or end load on shaft c. Hammering coupling on shaft	a. Replace. b. Design problem;consult engineer. c. Coupling bore should be slip fit on shaft.
7. Bursting of Fluid Supply Inlet or Outlet Lines	a. Excessive pressure	a. If high inertia load over runs motor relief valve protection is required in one or possibly both lines between directional valve and motor. Use closed center valve with caution. Relief valve protection probably required as described above.
8. Excessive Noise	a. Worn or damaged internal parts. b. Air in System	a. Disassemble to remove rotor, vane, cam ring assembly. Inspect for excessive wear. Check condition of faces of port plate and end cap. Rework (lap) or replace if scuffed. b. Bleed air off-check fittings for tightness.
9. Seal Failure	a. High drain line pressure on externally drained unit. b. High outlet pressure on internally drained unit.	a. Provide larger drain line. Provide shorter less restricted drain line. b. Revise circuit to reduce back pressure. Increase line size.

Problems encountered not indicated in this table should be referred to the Customer service Center or nearest Abex/Denison representative.

Section V OVERHAUL

GENERAL

The instructions contained in this section cover a complete disassembly, inspection and assembly of the vane type fluid motor.

Drain all fluid from the motor and thoroughly clean the exterior surface. Prepare a clean, lint-free surface on which to lay the internal parts of the motor.

SPECIAL TOOLS

No special tools are required to disassemble and reassemble this motor.

DISASSEMBLY

See Figure V for item numbers listed below.

1. Secure the motor in a vise or other suitable holding fixture with the shaft (18) extended down.
2. Remove screws (1) and remove the end cap (2) from the body.
3. Remove the rubber seal ring (3) from the end cap (2).
4. Check the needle bearing (4) in the end cap. If it is worn or damaged, remove it.
 - (a) See additional instructions on page 10 for disassembly of M1D1 internally drained end cap.
5. Remove the dowel pin (5) from the cam ring assembly (6).
6. Thread two #10-24 screws in the two tapped holes provided as puller holes in the cam ring (6a) and remove the cam ring assembly (6) as a unit (6a, 6b, 6c, 6d and 6e).

NOTE:

If resistance is encountered when lifting the cam ring assembly, lightly tap the outside of the body while lifting the assembly. This will help in removing the cam ring, rotor, vanes and springs as a unit.

WARNING!

The vanes are held against the cam ring by tension from the springs in the rotor. If the rotor is pulled from the cam ring with no protection, tension from the springs will throw the vanes out in all directions. The following procedure must be followed when disassembling the rotor and vanes from the cam ring.

Place the cam ring assembly on a clean, flat surface. Push the rotor and vanes from the cam ring far enough to secure a piston ring compressor over the vanes and around the rotor.

After the compressor is in place, push the rotor and vanes the remainder of the way out of the cam ring.

Release the tension on the compressor and remove the vanes (6c), spring guides (6e) and vane springs (6d) from the rotor (6b).

7. Remove dowel pin (7) from the port plate assembly.
8. Thread two 10-24 screws into the puller holes in the port plate assembly (8) and remove it from the body (19).
 - (a) Port plate assembly teardown:

Remove the 5/16 - 18 x 1/2" socket set screw in the side (Do not reuse if the nylon insert in the screw is badly damaged). Remove the 1/4 x 3/4 shuttle pin from the drilled passage. The drilled holes in the port plate must be clean and free from burrs.
9. Remove the rubber seals (9 & 10) and wavy washer (11).
10. Remove the snap ring (12) from the shaft.
11. The shaft seal assembly (13) contains eight parts, spring retainer, spring, steel band, rubber friction ring, shell, carbon ring, cast iron seat with a lapped face and an "O" Ring. Remove the spring retainer

and spring. Two #10-24 tapped holes are provided in the seat to remove the rest of the seal assembly as a unit.

"CAUTION"

DO not damage the carbon ring and the lapped surface of the cast iron seat.

12. Remove internal snap ring (14).
13. Press on external end of the shaft (17) and remove shaft and bearing (16) from the body.
14. Remove the external snap ring (15) and press the bearing from the shaft.

CLEANING & INSPECTION

1. Wash all metal parts in cleaning solvent (Stoddard Solvent or equal) and dry thoroughly.
2. Inspection of Parts.
 - (a) Inspect the seals for wear, breaks, cuts and brittleness. Check closely the lapped surface of the seal seat and the carbon ring of the shaft seal assembly for scratches and cracks. Discard and replace all defective seals.
 - (b) Inspect all springs for wear on the O. D., for cracks or permanent set. Replace all defective springs.
 - (c) Inspect bearings for wear or flat spots. If the bearings are rough or loose they must be replaced.
 - (d) Inspect the cam ring for excessive wear (ripples or washboard marks on the contour). Replace a badly worn or defective cam ring.
 - (e) Inspect the rotor for scored, marred or scratched (faces and vane slots) surfaces. Replace a defective rotor.
 - (f) Inspect the vanes for excessive wear marks (burrs, nicks and scoring). Replace defective vanes.
 - (g) Inspect the wear surfaces of the port plate and end cap for deep scratches. Replace if defective.
 - (h) Inspect the body and end cap for cracks or other casting damage. Replace all damaged castings.

- (i) Inspect the shaft for excessive wear (internal spline, bearing surface and drive end). Replace if defective.

"CAUTION"

Dirt is a major cause of wear and motor failure. Cover all parts after cleaning to prevent dust and dirt from settling on them. All surfaces should be coated with a film of hydraulic lubricating oil after they have been cleaned.

LUBRICATION

No external lubrication is required. The hydraulic fluid which operates the motor provides adequate internal lubrication. The shaft ball bearing is prelubricated and sealed.

REASSEMBLY

1. Press bearing (16) on the shaft (17) and install external snap ring (15). Be certain that the ring is seated in the snap ring groove. Press the shaft assembly into the body (19).
2. Install internal snap ring (14) in the groove in the body.
3. Installation of the seal assembly (13).

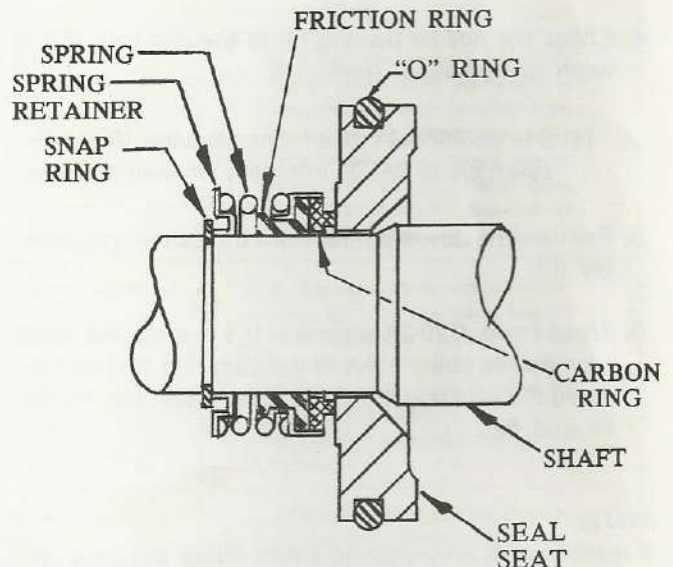

SHAFT SEAL DETAIL

"CAUTION"

Before installing the seal assembly, study and examine all of the parts. The seal seat and carbon ring have a precision finish and must be handled with care. Take particular care not to mar the lapped faces.

- (a) Place some oil on the inner surface of the rubber friction ring before installing it. Be certain there are no burrs or sharp edges on the shaft.
- (b) Apply heavy grease to the "O" Ring which is a part of the seal assembly and install on the cast iron seat. Insert the cast iron seal seat against the snapping (14) with the unfinished side facing the bearing (lapped surface facing out). Slide the shell containing the rubber friction ring and carbon ring over the internal splined end of the shaft. The carbon ring must seal against the lapped seat. Insert the coil spring over the friction ring and install the spring retainer on the spring. Depress the spring retainer and spring and install external snap ring (12) in the groove on the shaft.

4. Place the wavy washer (11) in the body.

5. Port Plate Sub-Assembly (8)

The special screws and the port plate including the internal threads must be degreased. Apply a very small amount of Loctite #242 to the special screws only. An excessive amount of Loctite on the screws would be forced into the shuttle spool bore when the screws are installed. Allow the Loctite to cure for one hour after installing the screws.

- (a) Install one of the special screws in the shuttle spool bore of the port plate. Torque screw to 9 to 10 ft. lbs. maximum. Insert the shuttle spool in the shuttle bore and install the other special screw and torque. Tilt the port plate subassembly back and forth to be certain that the spool travels the full length of the bore.

6. Apply heavy grease to seals (9) and (10) and install in grooves on the port plate.

7. Thread two 10-24 screws in the tapped hole in the face of the port plate assembly (8) and install in the body. See Fig. III for correct position.

8. Insert the dowel pin (7) in the port plate assembly.

9. Assemble the cam ring assembly (6) in this manner. Place the cam ring (6a), rotor (6b), vane springs (6d), spring guides (6e) and vanes (6c) on a clean flat surface. Arrange the vanes side by side with the three spring holes up. Insert the vane springs in the vanes, insert the spring guides in the springs. Install the vanes with the guides and springs in the slots in the rotor.

"WARNING"

Be certain that the heads of the spring guides and springs are started in the holes in each rotor slot.

- (a) Place a ring compressor around the vanes and tighten the compressor gradually until the springs and vanes are in the position they will occupy while in the cam ring. Place a back up plate, slightly smaller than the outside diameter of the rotor in the ring compressor and push the rotor, springs and vanes into the cam ring. The back up plate will prevent the vanes from sliding end wise in the rotor slots and damaging the slots and springs.

"WARNING"

Be certain that the rotor and vane assembly is inserted far enough in the cam ring to prevent the vanes from flying out of position when the ring compressor is removed.

10. Thread two #10-24 screws into the cam ring assembly on the same side of the ring that indicates the cam size. Insert the dowel pin (5) in the cam ring and position the complete assembly in the body over the dowel pin (7).

11. Apply heavy grease to the rubber seal (3) and install in the groove in the cap (2).

12. Press the needle bearing (4) into the end cap (2) with markings on the bearing 1/16" below the face of the cap.

- (a) See Additional instructions on page 10 for reassembly of M1D1 internally drained end cap.

13. Position the end cap (2) over the dowel pin (5). Hold the end cap firmly against the cam ring assembly and rotate to line up the bolt holes.

14. Insert screws (1) and tighten evenly to 130 ft. lbs. torque.

SPECIAL INSTRUCTIONS
M1D1 Internally Drained Cap Assembly
Code Number S14-16936

DISASSEMBLY

Remove the hex head plug (22) from the fluid connection face. Remove the two 3/8" socket pipe plugs (20) from the side of the cap (23). Remove the two check valves (21) located at the bottom of the ports. Check the needle bearing (4) in the cap (23). If it is damaged or worn, remove it.

Wash the cap and all parts in cleaning fluid and dry thoroughly.

Inspect the bearing, check valves, plugs and "O" ring. Make certain that all drilled and cored passages are open and clean. Carefully check the spring and ball in

the check valves. The ball must seat for the checks to function. If any parts are defective, they must be replaced.

REASSEMBLY

Lubricate both check valves (21). Install one check valve in each of the two tapped holes in the side of the cap (23). Install the two 3/8" socket pipe plugs (20). Press the needle bearing (4) in the end cap (23) with the marking on the bearing 1/16" below the face of the end cap. Install the hex head plug (22) with "O" ring in the fluid connection face.

S14-16936 CAP ASSEMBLY

ITEM	PART NUMBER	DESCRIPTION	QUANTITY
4	230-82002	Needle bearing BH 12	1
20	431-90600	3/8" socket pipe plug	2
21	S14-01257	Check valve	2
22	488-06090	Hex head plug with "O" ring $\frac{1}{16}$ -18	1
23	034-44268	End cap	1

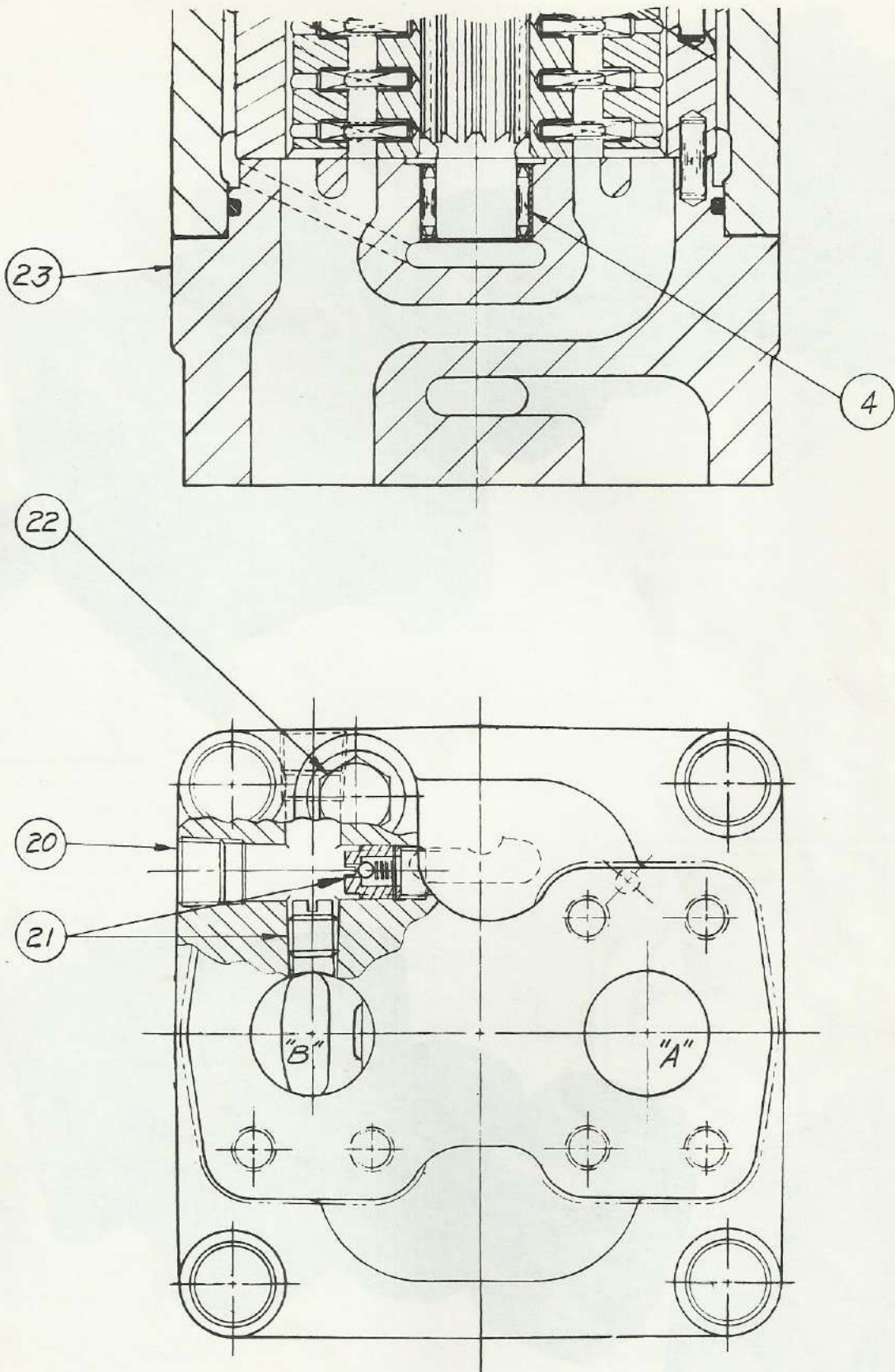

FIG. II
S14-16936 CAP ASSEMBLY

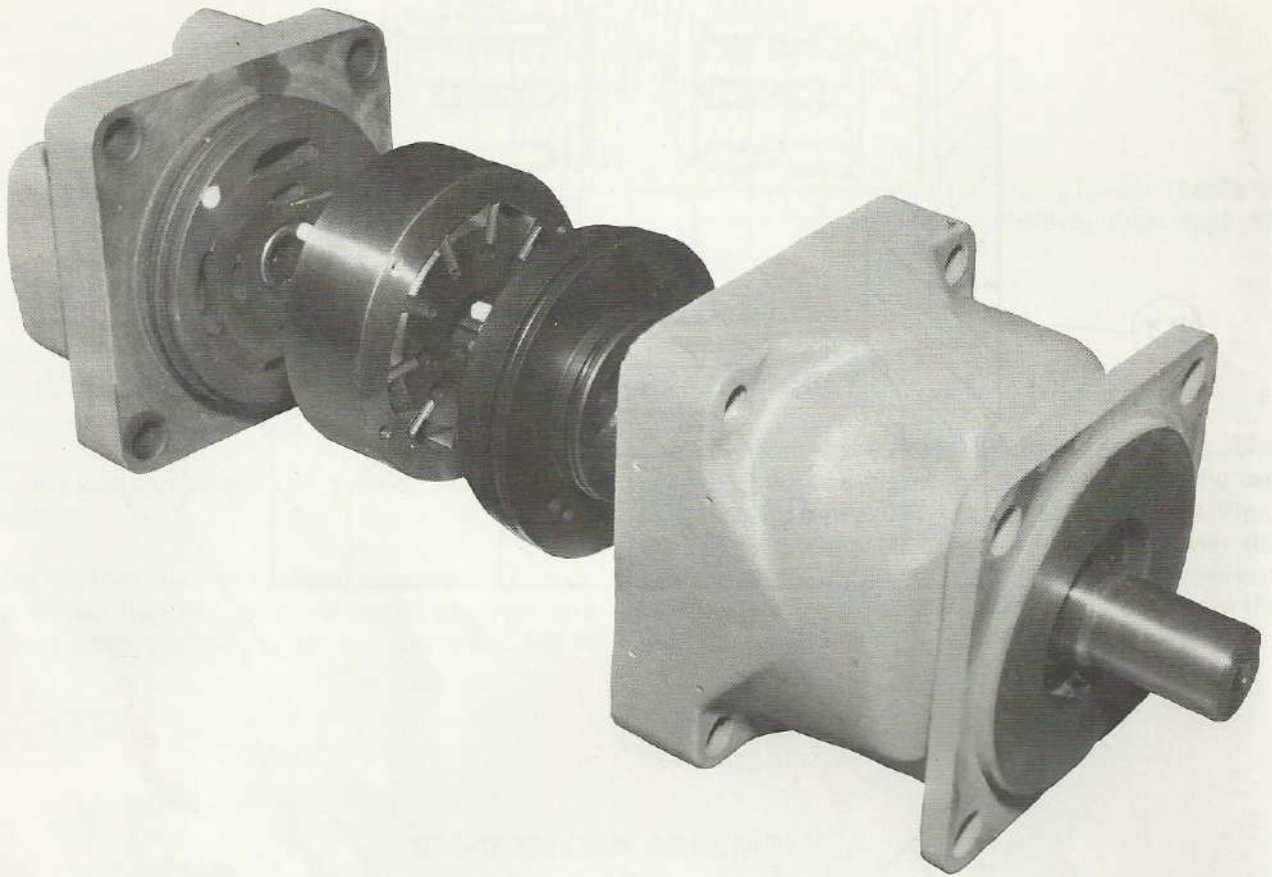
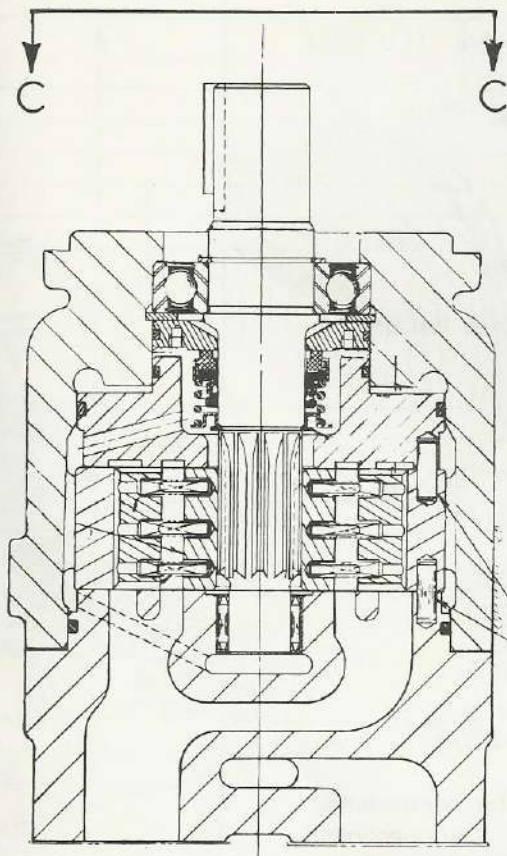
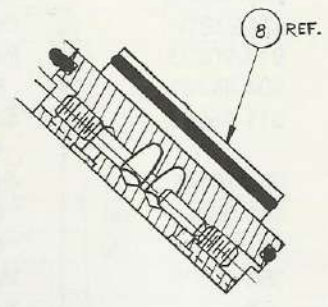

FIG. III



SECTION A-A



SECTION B-B

PINS SHOWN 45°
OUT OF POSITION

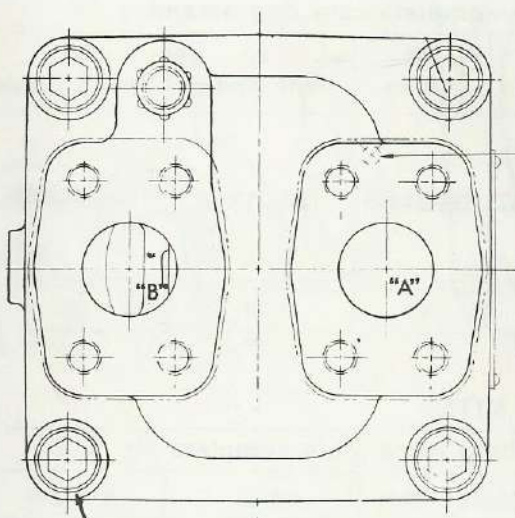

TIGHTEN TO 130
FT. LBS. TORQUE
4 BOLTS

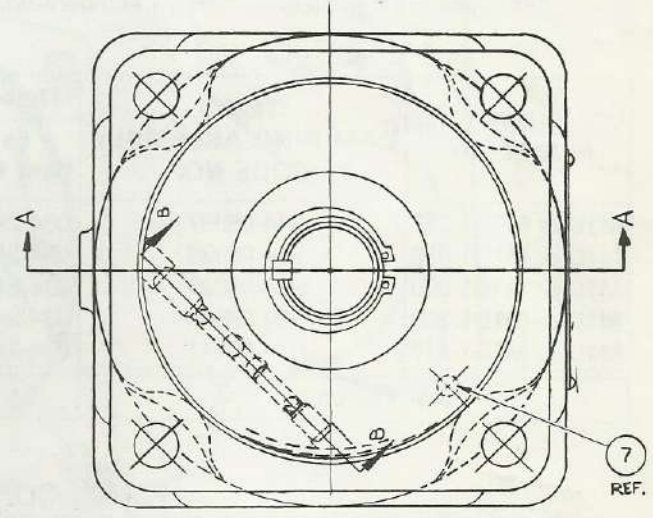

VIEW C-C

FIG. IV
M1D SERIES

M1D PARTS LIST

ITEM	PART NUMBER	DESCRIPTION	QUANTITY
1.	358-24260	Socket head cap screws 5/8 - 11 x 2 1/4	4
2.	034-24579	End Cap	1
3.	691-00248 (s)	"O" Ring 90-6230-26	1
4.	230-82002	Needle bearing BH-1312	1
5.	324-21612	Dowel Pin 1/4 x 3/4	1
6.	See Below	Cam ring assembly	1
7.	324-21612	Dowel Pin 1/4 x 3/4	1
8.	S14-20523	Front Port Plate Assembly	1
	034-48760	Front Port plate	1
	311-45020	Soc. set screw 5/16-18x1/2 flat point w/ Spotlok	2
	034-70341	Shuttle spool	1
9.	691-00246 (s)	"O" ring 90-6230-24	1
10.	691-00146 (s)	"O" ring 90-914-46	1
11.	350-10025	Wavy Washer #2332	1
12.	356-31112	External snap ring #5100-112	1
13.	623-11278 (s)	Shaft seal assembly	1
14.	356-32283	Internal snap ring 5008-283	1
15.	356-31137	External snap ring 5100-137	1
16.	230-99507	Ball bearing (double seal)	1
17.	034-24326	Shaft with keyway - # 21	1
	034-24327	Shaft with spline - # 23	1
18.	034-24311	Shaft key use with 034-24326	1
19.	034-24581	Body	1
(s)	S14-18564	Seal kit (includes seals for connections)	
	*S14-18564-S4	Seal kit (includes seals for connections)	
	**S14-18564-S5	Seal kit (includes seals for connections)	

*Phosphate Ester Fluid **High Temperature Petroleum Base & Synthetic Fluid

UNIT MODEL NO.	ITEM 6 CAM RING ASSEMBLY CODE NO.	These parts are a complete cam ring assembly				
		6a Cam Ring	6b Rotor	6c Vanes	6d Vane Spring	6e Spring Guide
M1D or M1D1-062	S14-08937	034-24682				
M1D or M1D1-086	S14-08938	034-24683				
M1D or M1D1-095	S14-08939	034-24684	034-21383	034-24848	034-21396	034-24678
M1D or M1D1-108	S14-08940	034-24685				
M1D or M1D1-117	S14-08941	034-24686				
Qty. Per Unit		1	1	10	30	30

FLUID CONNECTION KITS

			These parts are a complete kit		
MODEL NO.	CODE NO.	THREAD SIZE	CONNECTION	SEAL	SCREW
FS4-P-20-12-32	S14-06617	1 1/4" NPTF	034-24189	671-00233	7/16-14 x 2 1/4
FS4-W-20-12-36	S14-08055	1 1/4" IPS Socket Weld	034-24347	691 10224	7/16-14 x 2 1/4
FS4-S-26-13-38	S14-06618	SAE 20 (1 5/8-12)	034-24190	671-00223	7/16-14 x 1 1/2
Quantity			1	1	4

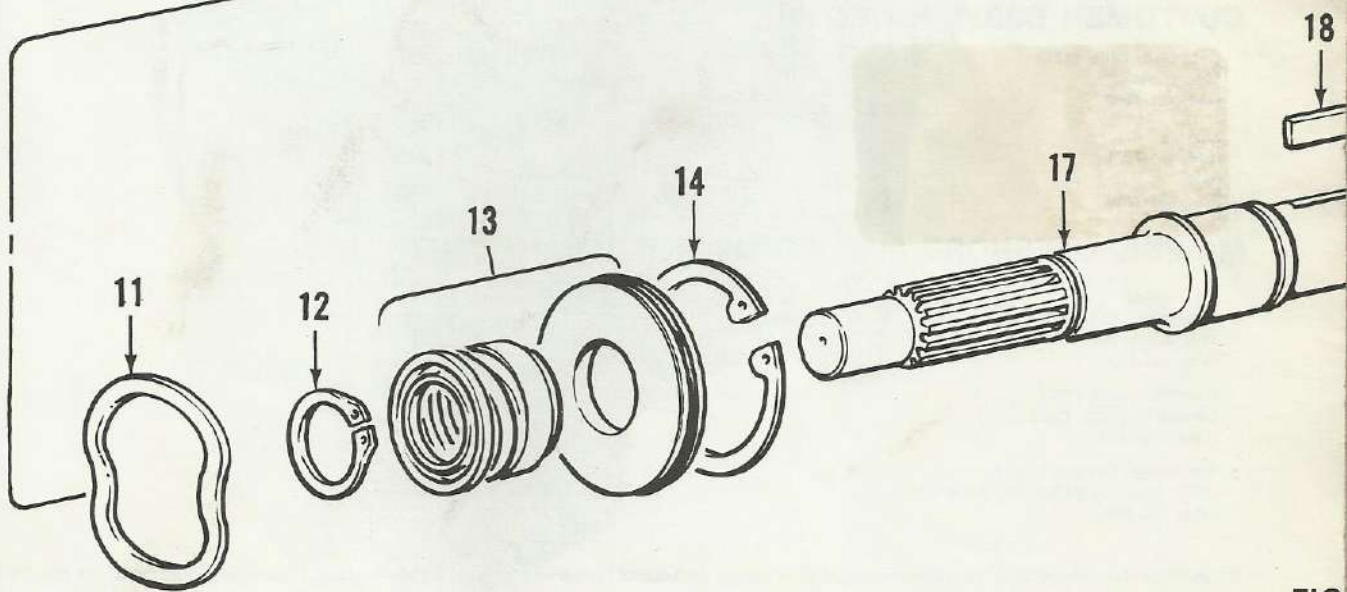
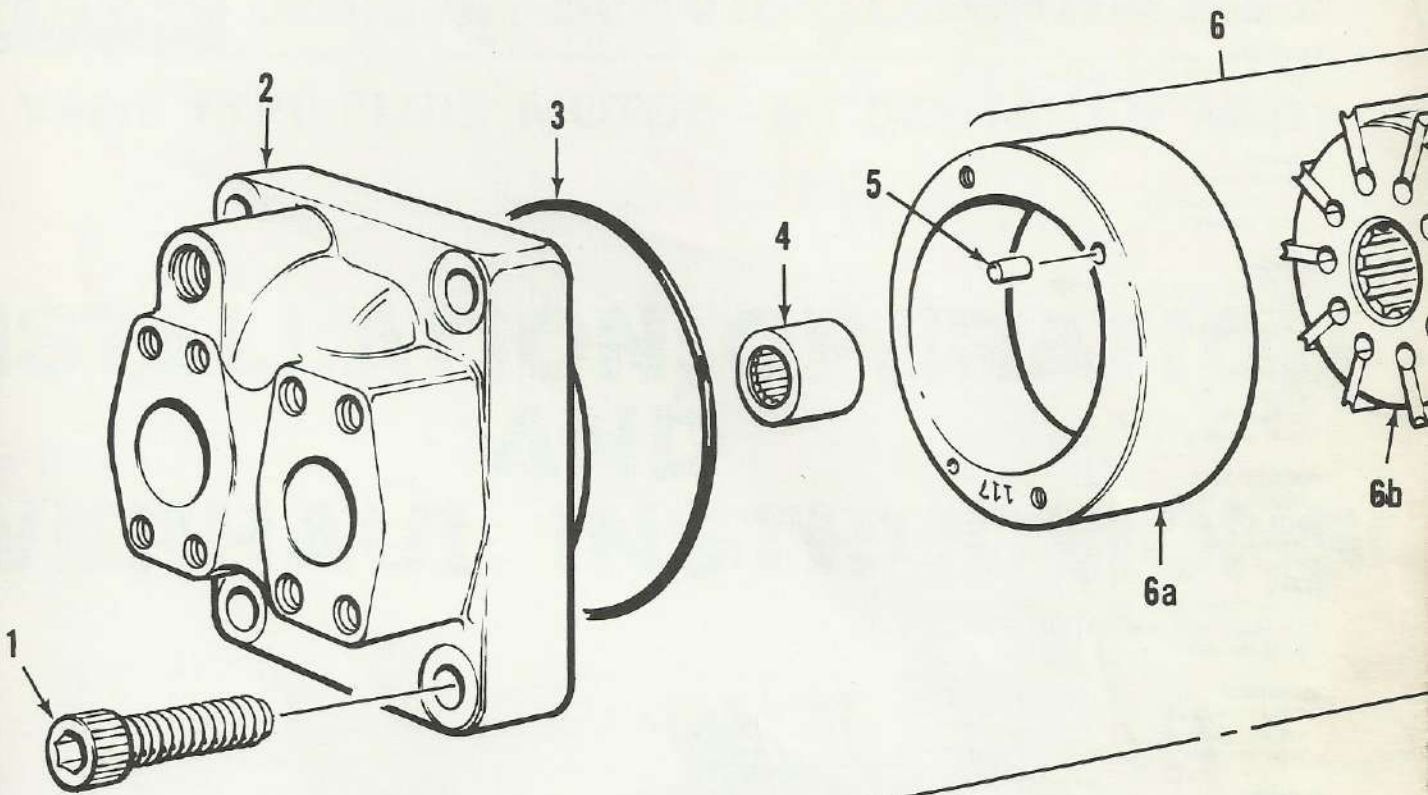

FIG

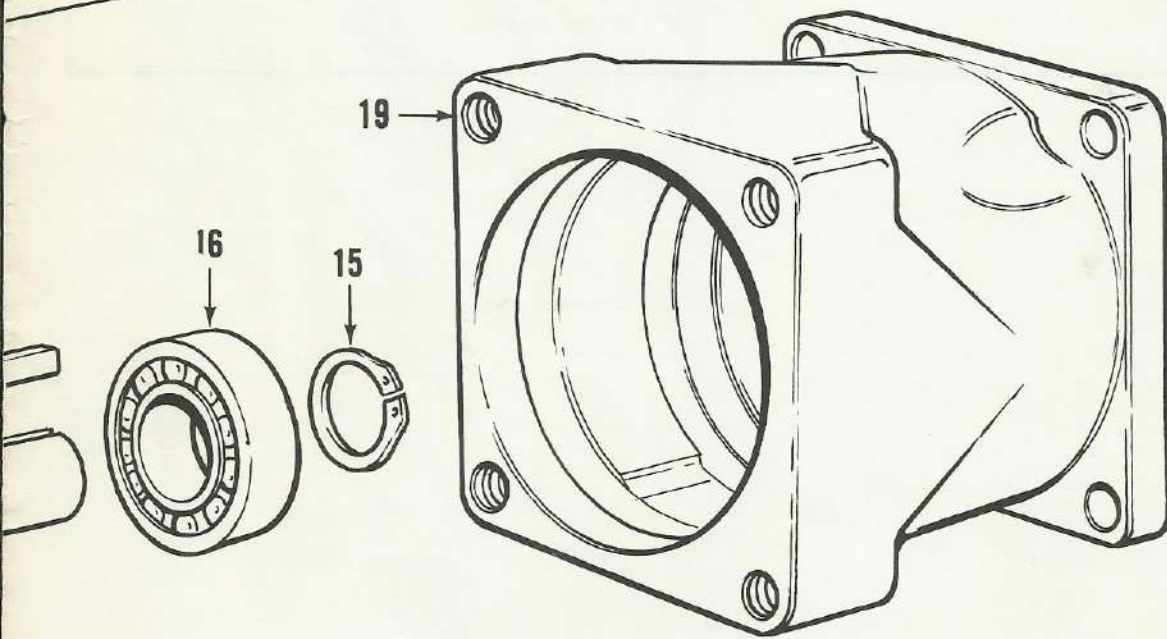
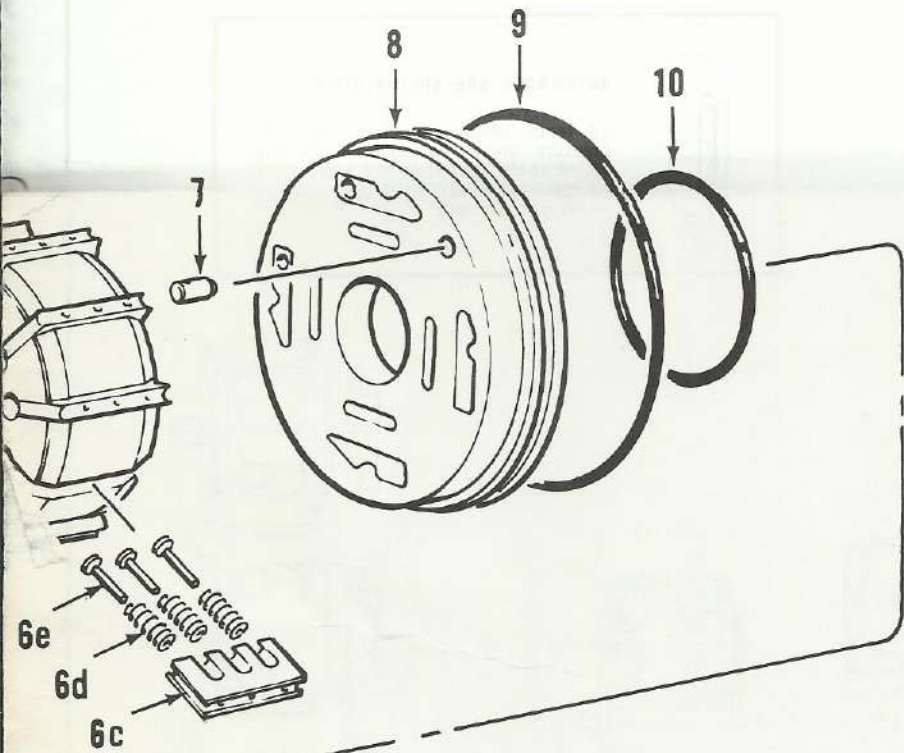

V

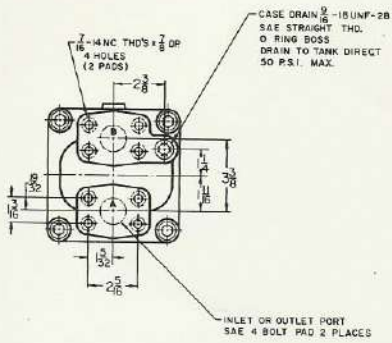

ALTERNATE SAE SPLINE SHAFT

14 teeth 12/24 diametral pitch, 30° pressure angle. To order motor with spline shaft, substitute the suffix "23" for the suffix "21" in model numbers in table to the left.

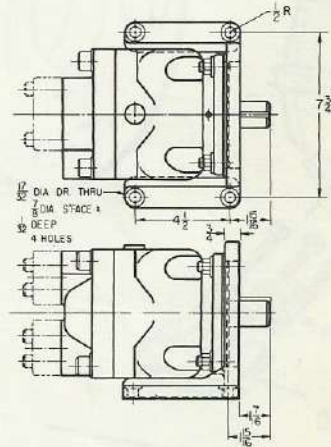
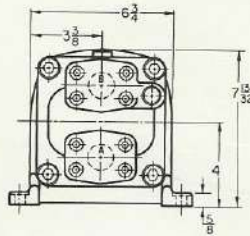
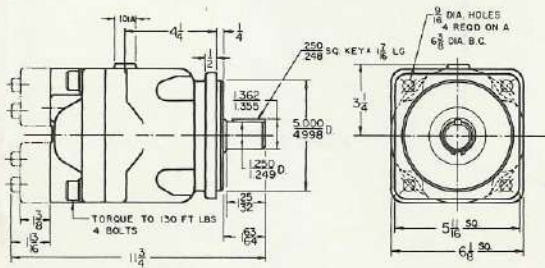

M1D Flange Mounted.

M1D Bracket Mounted.

GENERAL SALES OFFICES

CALIFORNIA

Los Altos (San Francisco) 94022
175 S. San Antonio Rd.
(415) 948-5736

GEORGIA

Atlanta 30342
174 W. Wieuca, N.E.
(404) 252-3417

ILLINOIS

La Grange (Countryside) 60525
5344 East Ave.
(312) 354-8134

NEW YORK

Chatham 12037
18 Main St.
(518) 392-5210

PENNSYLVANIA

Pittsburgh 15220
1910 Cochran Rd., Manor Oak 1 Bldg.
(412) 343-5313

TEXAS

Dallas 75240
7540 LBJ Expressway, Suite 913
(214) 239-0963

WISCONSIN

Elm Grove 53122
910 Elm Grove Rd.
(414) 786-9590

CANADA

Abex Industries Ltd., Denison Division
Downsview, Ontario
681 Petrolia Rd.
(416) 861-9633

CUSTOMER SERVICE CENTER

Columbus, Ohio 43216
1200 Dublin Rd.
(614) 481-7262

Service
(614) 481-7271
Parts
(614) 481-7260

MARINE, OFFSHORE & GOVERNMENT DEPARTMENT

Main Office
Columbus, Ohio 43216
1160 Dublin Rd.
(614) 481-7200

Houston, Texas 77060
12620 I-45 North, Suite 107
(713) 443-6540

San Diego, California 92121
11772 Sorrento Valley Rd., Suite 252
(714) 481-8966

Sales Representatives and Distributors Located in Major Industrial Areas—Look for "Abex/Denison Hydraulic Equipment" in the Yellow Pages.

INTERNATIONAL SUBSIDIARIES AND SALES OFFICES LOCATED IN—Argentina, Australia, Austria, Belgium, Brazil, Canada, Chile, Colombia, Denmark, Eastern Europe, England, Finland, France, Germany, Greece, Holland, India, Iran, Italy, Japan, Mexico, New Zealand, Norway, Peru, South Africa, Spain, Sweden, Switzerland, Turkey, Venezuela.



ABEX CORPORATION, DENISON DIVISION, 1160 Dublin Road, Columbus, Ohio 43216 (614) 481-7200
An IC Industries Company