

Check Valves



Right Angle Check Valves

C2-800 Series

When ordering replacement parts, furnish complete model number and part number. Do not order by index reference alone.

See Tabulation Below and on Reverse Side

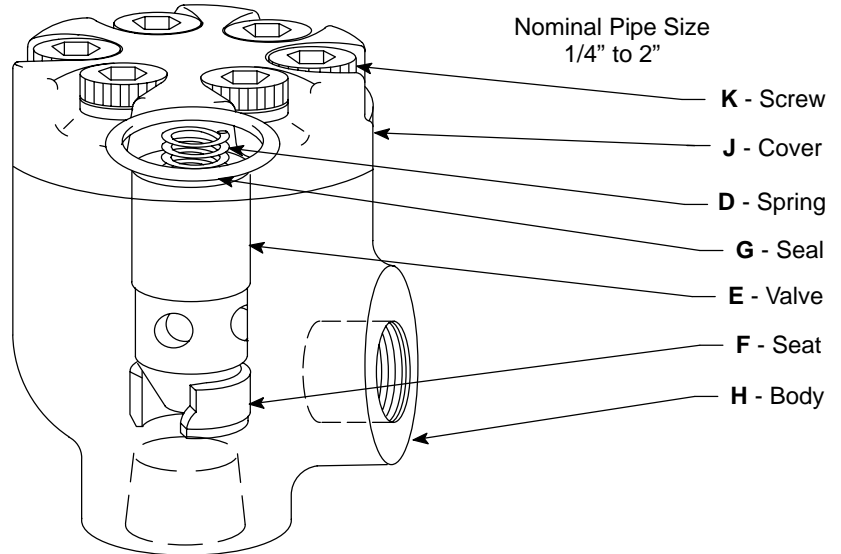

Spacer	Model used on
64329	C2-800-S17 C2-805-S17
109738	C2-820-S17

-S17 Design

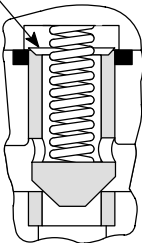

-S12 Design

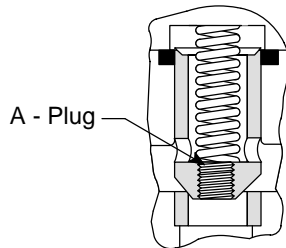

-S18 Design

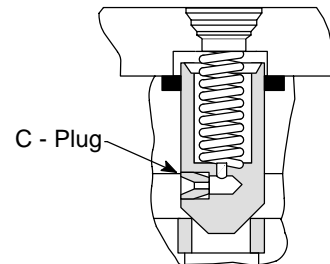

Pipe Size	Model	A Plug	B Cracking Pressure PSI	C Plug	D Spring	E Valve	F Seat	G 'O' Ring Seal	H Body	J Cover	K Screw (6 req'd)	
1/4"	C2-800	-	5	-	2978	118-X	913-X	262339	94100	5657	1050	
	C2-800-S2	-	35	-	31717							
	C2-800-S3	-	50	-	35298							
	C2-800-S8	-	75	-	55233	54097						
	C2-800-S12	81593	5	-	2978							
	C2-800-S17	-	125	-	112407	118-X						
	C2-800-S19	-	20	-	65915							
C2-800-S20	-	1	-	140804	118-X							
3/8"	C2-805	-	5	-		2978	118-X	913-X	262339	94100	5657	1050
	C2-805-S2	-	35	-		31717						
	C2-805-S3	-	50	-		35298						
	C2-805-S8	-	75	-		55233	54097					
	C2-805-S12	81593	5	-		2978						
	C2-805-S17	-	125	-		112407	118-X					
	C2-805-S19	-	20	-	65915							
C2-805-S20	-	1	-	140804								

Pipe Size	Model	A Plug	B Cracking Pressure PSI	C Plug	D Spring	E Valve	F Seat	G 'O' Ring Seal	H Body	J Cover	K Screw (6 req'd)
1/2"	C2-810	-	5	-	2943	2714	2715	262395	94010	94099	1071
	C2-810-S2	-	35	-	36316						
	C2-810-S3	-	50	-	25896						
	C2-810-S8	-	75	-	32999						
	C2-810-S12	81592	5	-	2943	48936				2714	
	C2-810-S17	-	125	-	84235						
	C2-810-S18	-	5	62014	49178	75928					
	C2-810-S19	-	20	-	2287	2714					
	C2-810-S20	-	1	-	83902						
3/4"	C2-815	-	5	-	2943	2714	2715	262395	94015	94099	1071
	C2-815-S2	-	35	-	36316						
	C2-815-S3	-	50	-	25896						
	C2-815-S8	-	75	-	32999						
	C2-815-S12	81592	5	-	2943	48936				2714	
	C2-815-S17	-	125	-	84235	2714					
	C2-815-S18	-	5	62014	49178	75928					
	C2-815-S19	-	20	-	2287	2714					
	C2-815-S20	-	1	-	83902						
1"	C2-820	-	5	-	2990	6422	6423	262401	94020	94098	1073
	C2-820-S2	-	35	-	60290						
	C2-820-S3	-	50	-	19767						
	C2-820-S8	-	75	-	45685						
	C2-820-S12	81592	5	-	2990	58781				6422	
	C2-820-S17	-	125	-	109735	6422					
	C2-820-S18	-	5	62014	99977	10004					
	C2-820-S19	-	20	-	39067	6422					
	C2-820-S20	-	1	-	104485						
1-1/4"	C2-825	-	5	-	2284	2587	2937	262402	94025	94097	1073
	C2-825-S2	-	35	-	2953						
	C2-825-S3	-	50	-	29059						
	C2-825-S8	-	75	-	39778						
	C2-825-S12	81591	5	-	2284	58782				2587	
	C2-825-S17	-	125	-	64062	2587					
	C2-825-S18	-	5	62014	18493	66207					
	C2-825-S19	-	20	-	106669	2587					
	C2-825-S20	-	1	-	2950						
1-1/2"	C2-830	-	5	-	2284	2714	2937	262402	94030	94097	1073
	C2-830-S2	-	35	-	2953						
	C2-830-S3	-	50	-	29059						
	C2-830-S8	-	75	-	39778						
	C2-830-S12	81591	5	-	2284	48936				2714	
	C2-830-S17	-	125	-	64062	2714					
	C2-830-S18	-	5	62014	18493	75928					
	C2-830-S19	-	20	-	106669	2714					
	C2-830-S20	-	1	-	2950						
2"	C2-835	-	5	-	9803	10748	10749	262410	94035	10746	1115
	C2-835-S2	-	35	-	10766						
	C2-835-S3	-	50	-	44425						
	C2-835-S8	-	75	-	105614						
	C2-835-S12	81590	5	-	9803	58783				10748	
	C2-835-S17	-	125	-	234965	10748					
	C2-835-S18	-	5	51305	65939	65667					
	C2-835-S19	-	20	-	79798	10748					
	C2-835-S20	-	1	-	114304						