

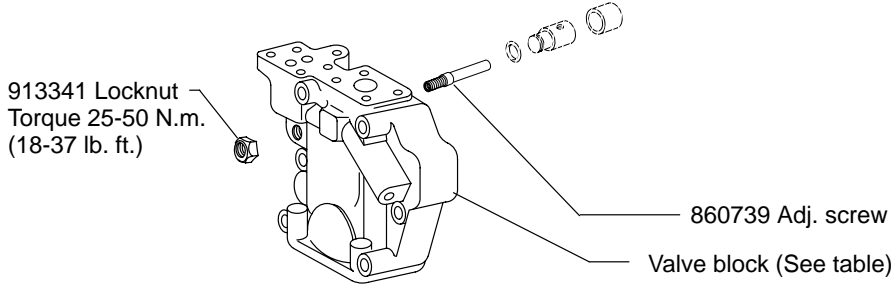

PVH131/141 Variable Displacement Piston Pump - 11 Design

Maximum Adjustable Stop – S Option



Valve Block Table		
Pump Type	RH	LH
F-11-C	928637	928687
M-11-C	928638	928688
SF-11-C	928624	928673
SM-11-C	928625	928674
F-11-CT	860852	860861
M-11-CT	860853	860862

Torque Limiter – T Option

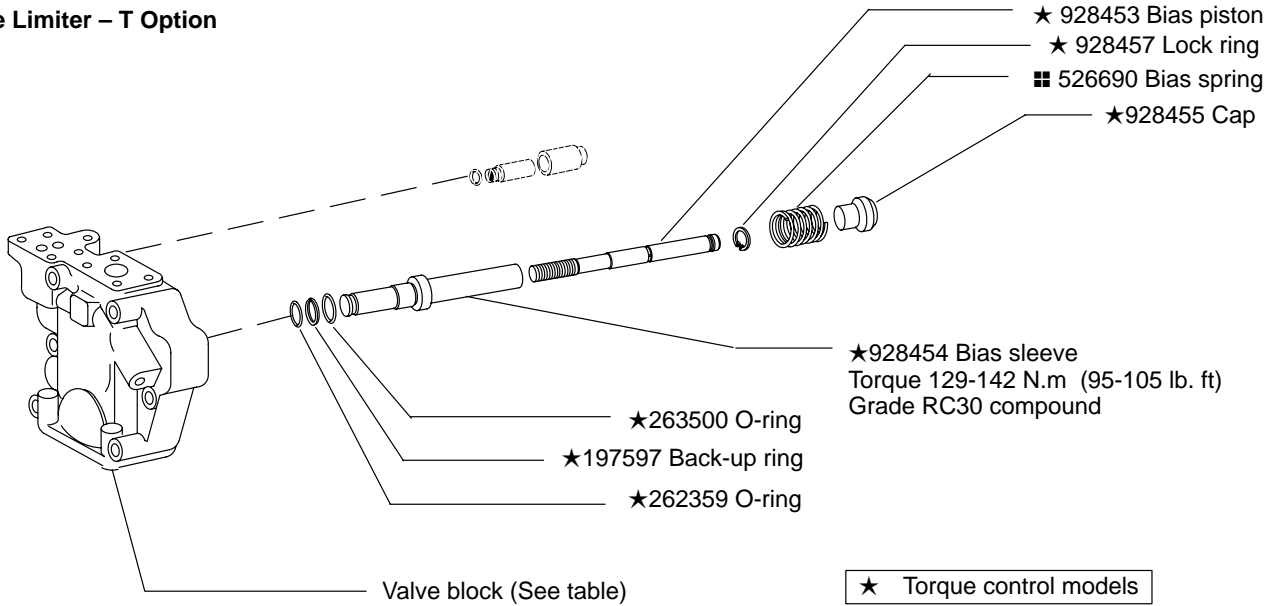

Standard – C/CM/CMV/CV/IC

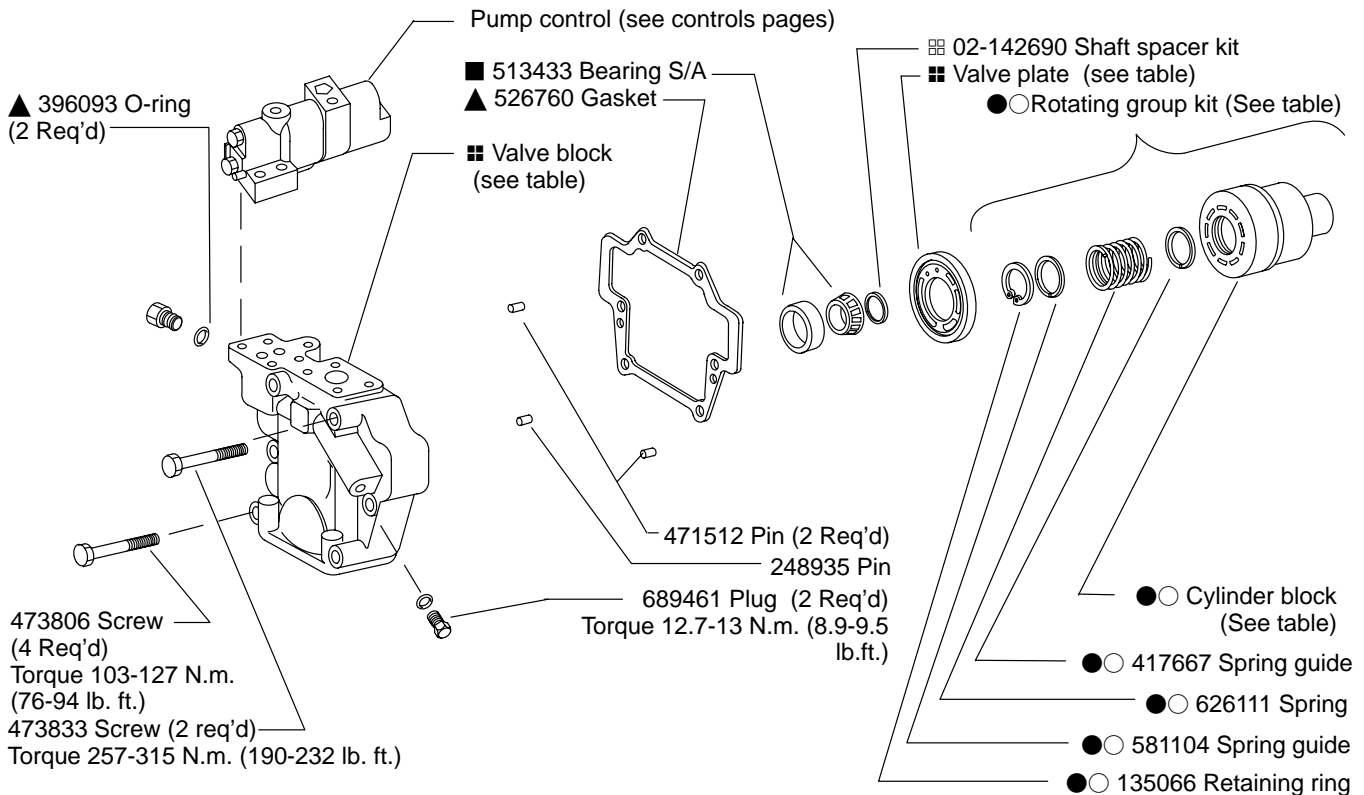

Housing	Flange/Seal
692944	-C-*S
876277	-C-*D
864310	-C3-*S

Model Designation	Piston & Shoe S/A (9 req'd)	Cylinder Block	Shoe Cage	Rotating Group Kit
● 131 Size	02-159749	680628	683791	● 877419
○ 141 Size	02-306332	928786	928776	○ 02-322898

Note
Complete replacement via rotating group kits is recommended.

Valve Plate Table		
Pump Type	RH	LH
131	527164	527163
131QI	864381	876045
131QP	913578	N/A
141	928774	934240
141QI	934242	934243
141QP	934241	N/A

Shaft	Type	Key
876177	3 - Splined thru-drive	-
860594	12 - Splined thru-drive	-
876176	16 - Straight keyed thru drive	633260
860802	2 - Splined	-
877042	3 - Splined	-
860593	12 - Splined	-
876175	13 - Straight keyed	140282

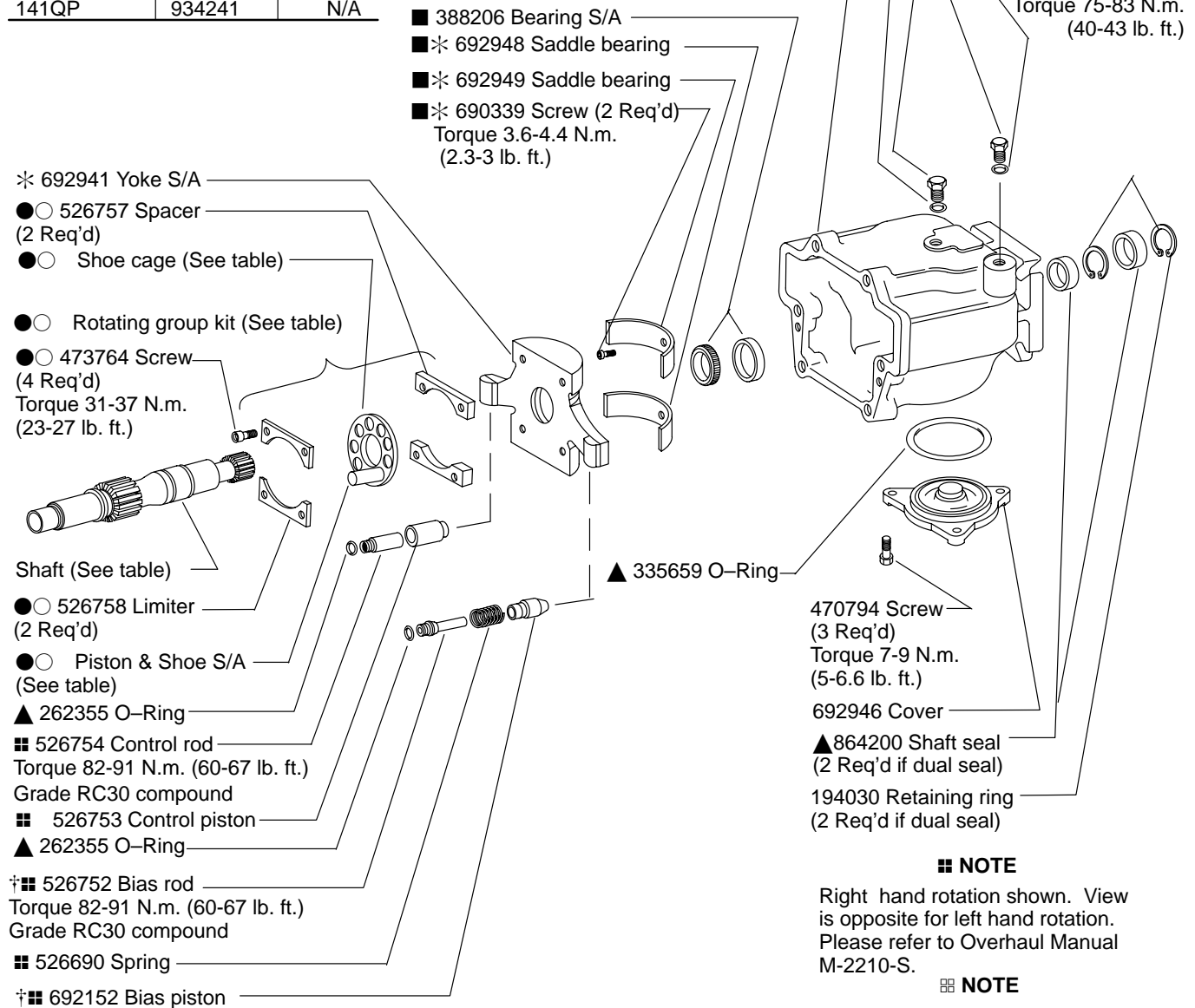

† Non-torque control models

▲ Available in double shaft seal kit 02-102266

■ Available in bearing kit 877426

* Available in bearing/yoke kit 02-334838

● Available in PVH131 rotating group kit.

○ Available in PVH141 rotating group kit.

NOTE

Right hand rotation shown. View is opposite for left hand rotation. Please refer to Overhaul Manual M-2210-S.

NOTE

Use shims as required to obtain 0.01-0.10 mm (.0004-.004 in.) axial shaft end play.

NOTE

For satisfactory service life of these components in industrial applications, use full flow filtration to provide fluid which meets cleanliness code 16/14/12 or cleaner.

Load Sensing & Pressure Compensator Control C(M)*V

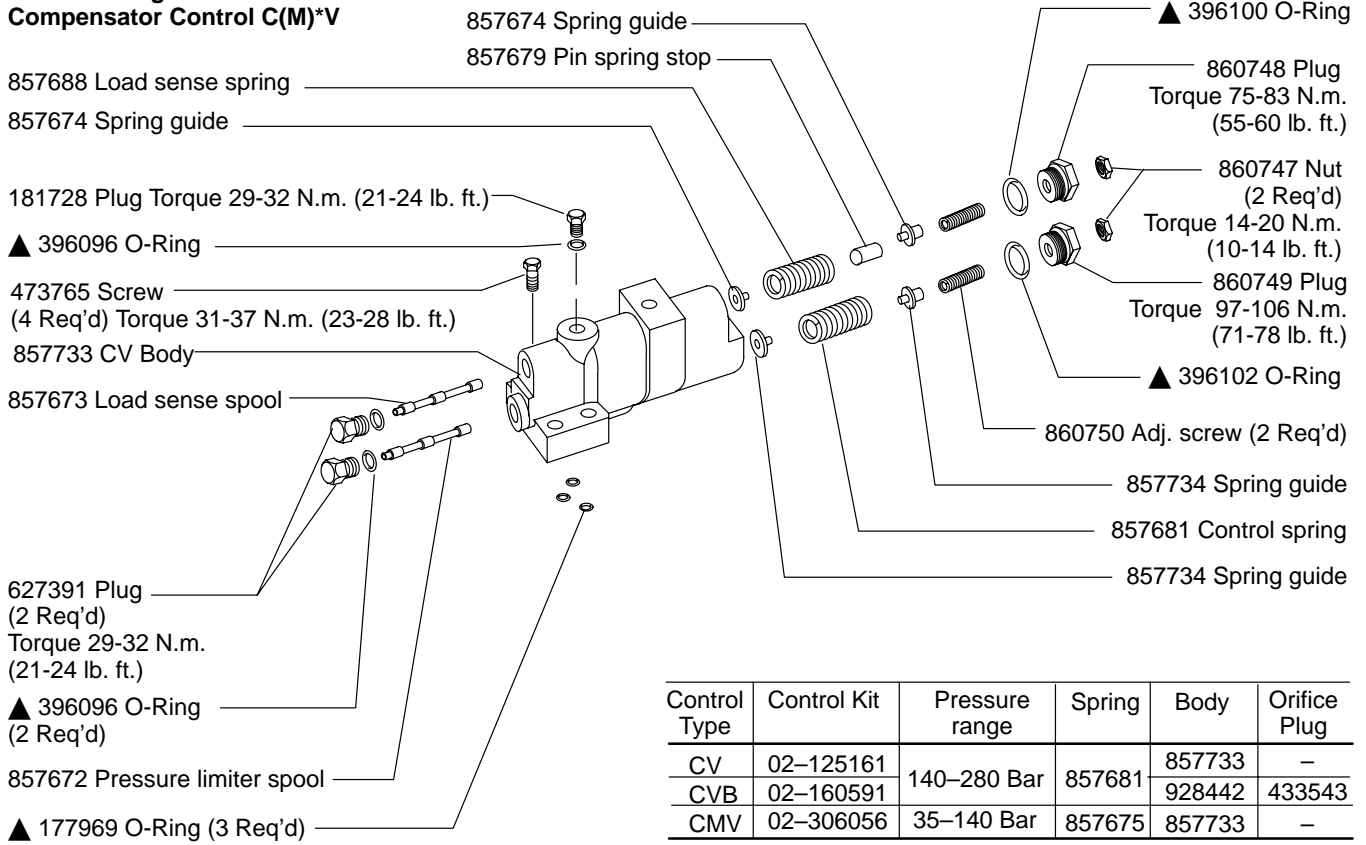

Control Type	Control Kit	Pressure range	Spring	Body	Orifice Plug
CV	02-125161	140-280 Bar	857681	857733	-
CVB	02-160591			928442	433543
CMV	02-306056	35-140 Bar	857675	857733	-

All parts shown are included in control kit.
Kit must be set by user to circuit requirements.

Pressure Compensator Control C & CM

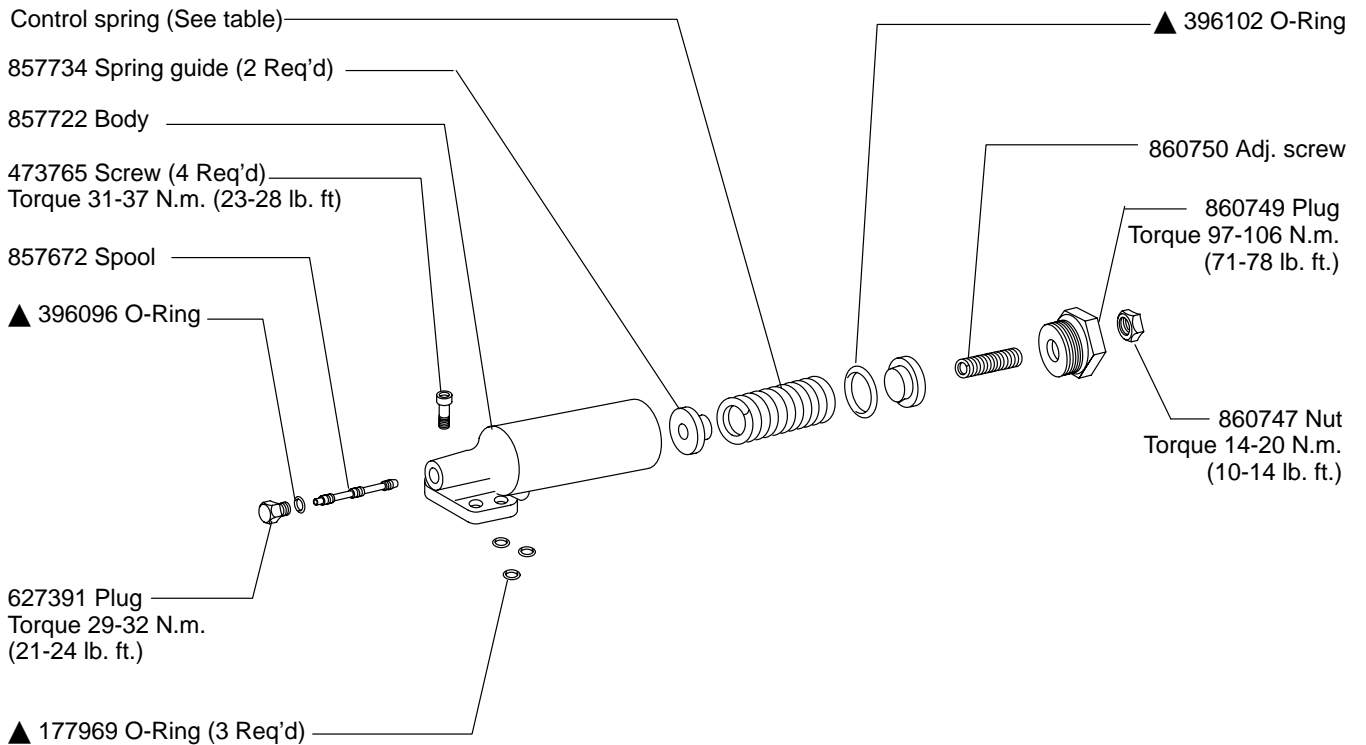

Control Type	Control Kit	Pressure range	Spring
C	02-125160	70-250 Bar	857681
CM	02-125162	40-130 Bar	857675

All parts shown are included in control kit.
Pressures must be set by user to circuit requirements.

Industrial Control (IC)

- 473769 Screw (2 Req'd)
Torque 31-37 N.m. (23-28 lb. ft.)
- 407533 Plug
Torque 12.1-12.4 N.m. (8.9-9.1 lb. ft.)
- ▲ 396093 O-Ring
- ▲ 396092 O-Ring (3 Req'd)
- 398071 Plug (3 Req'd)
Torque 9.8-10.2 N.m. (7.2-7.5 lb. ft.)
- Body (see table)
- 626157 Spring
- 860606 Spring guide (2 Req'd)
- ▲ 396100 O-Ring
- 860747 Nut
Torque 14-20 N.m.
(10-14 lb. ft.)
- 860750 Adj. screw
- 860748 Plug
Torque 75-83 N.m. (55-60 lb. ft.)

Control Kit	Threads	Body
02-151906	inch	883386
02-151907	metric	860628

All parts shown are included in control kit. Pressures must be set by user to circuit requirements.

- (2 Req'd) Torque 31-37 N.m. (23-28 lb. ft.)
- 473765 Screw
- ◇ 113000 Plug
Torque 5.1-5.9 N.m. (3.7-4.4 lb. ft.)
- 860566 Orifice plug
Torque 1.7-2.3 N.m.
(1.2-1.7 lb. ft.)
- ▲ 396096 O-Ring
- ◇ 181728 Plug
Torque 29-32 N.m.
(21-24 lb. ft.)
- 627391 Plug
Torque 29-32 N.m.
(21-24 lb. ft.)
- ▲ 396096 O-Ring
- 939816 Spool
- ▲ 177969 O-Ring
(2 req'd)
- ▲ 216630 O-Ring

◇ NOTE

IC kits pre-set to 20-30 bar differential pressure with all orifices/plugs in place. Reference Vickers Overhaul Manual M-2210-S for proper orifice/plug configuration in various circuits prior to control installation.

Torque Limiter – T Option

- 860749 Plug
Torque 75-83 N.m
(102-112 lb. ft.)
- 860750 Adjusting Screw
- 860747 Nut
Torque 8-10 N.m
(11-14 lb. ft.)
- 1649 Ball
- 471627 Pin
- 937272 Check valve
Torque 1.7-2.3 N.m
(2.3-3.1 lb. ft.)
- 217669 O-ring
- 177969 O-ring
(2 req'd)
- 913454 Spool
- 860653 Body
- 177969 O-ring (5 req'd)
- 577639 Sleeve
- 262499 O-ring
- 248845 Pin
- ◆ 932716 Retainer Ring
(Screw into bottom of thread)
- 928388 Guide
- 857675 Spring
- 857734 Guide
- 263069 O-ring
- 913453 Guide
- 473773 Screw (4 req'd)
Torque to 31-37 N.m
(42-50 lb. ft.)
- 197594 Back-up ring
- 262356 O-ring
- 860655 Plug Torque 75-83
N.m (102-112 lb. ft.)
- ◆ 248823 Pin
- 186580 Plug
Torque 54-59 N.m
(73-80 lb. ft.)
- 263497 O-ring
- 113000 Plug
Torque 15-17 N.m
(20-23 lb. ft.)
- ◆ 932716 Connector
Torque 54-59 N.m
(73-80 lb. ft.)
- ◆ 263497 O-ring

Model designation	Control Kit
C**T**-31	02-314944
C**T**S-31	02-335254

◆ Torque summation parts

A Thru-drive

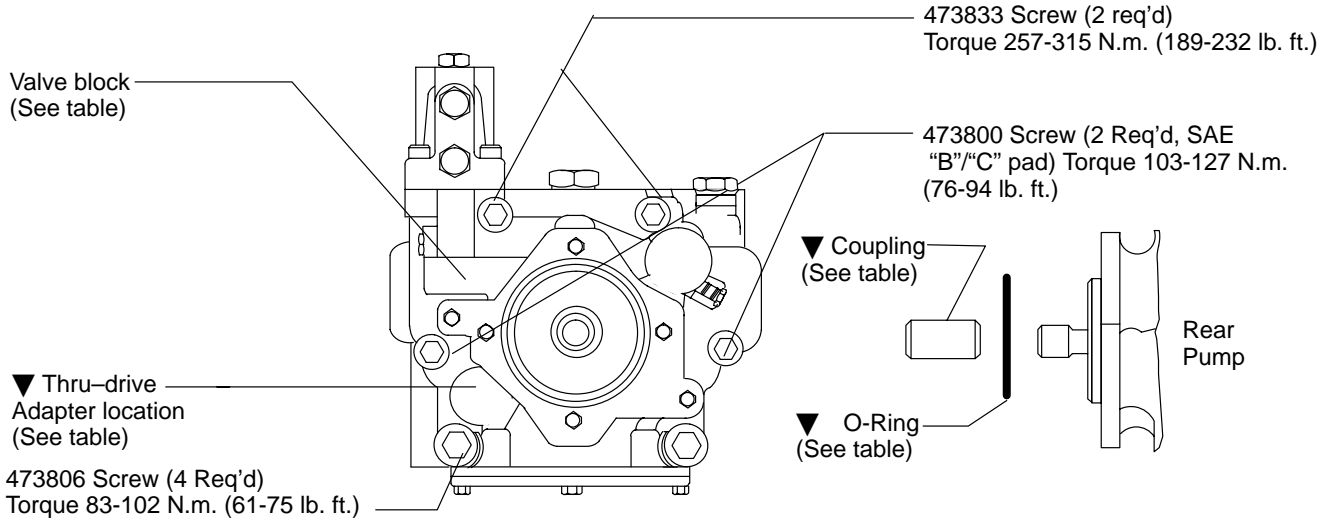

"A" Thru-drive

Model designation	Valve block w/ SAE "A" Pad	O-Ring	Coupling Type
LAF-11-C*	928713	576601	877039
LAM-11-C*	928714		
RAF-11-C*	928736		
RAM-11-C*	928737		
LAF-11-CT	860843		
LAM-11-CT	860844		
RAF-11-CT	860834		
RAM-11-CT	860835		

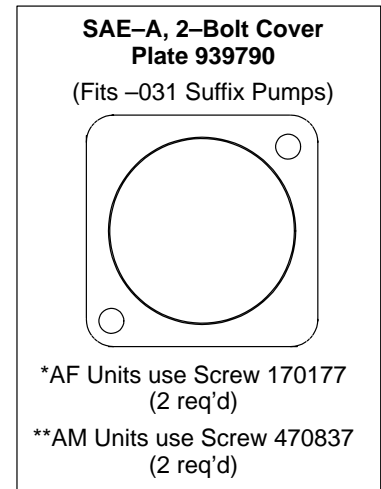

▼ "B" & "C" Thru-drive Adapter

Model Designation	Adapter Pad Kit	Adapter Flange	O-Ring	Coupling Types
-BF-11-	876390	526670	401525	877040 SAE-B 13 tooth
-BM-11-	876394	876393		877044 SAE-BB 15 tooth
-CF-11-	876389	692934	353264	877045 SAE-C 14 tooth
-CM-11-	876392	876391		877046 SAE-CC 17 tooth

Notes:

1. "F" type equal SAE threads
2. "M" type equal metric threads
3. "B" and "C" thru-drives created from "A" thru-drive pump with "B" or "C" thru-drive adapter kit installed.
4. All screws/O-rings are included with each "kit" to convert from "A" to "B" or "C" thru-drive unit.

Typical Cross Section

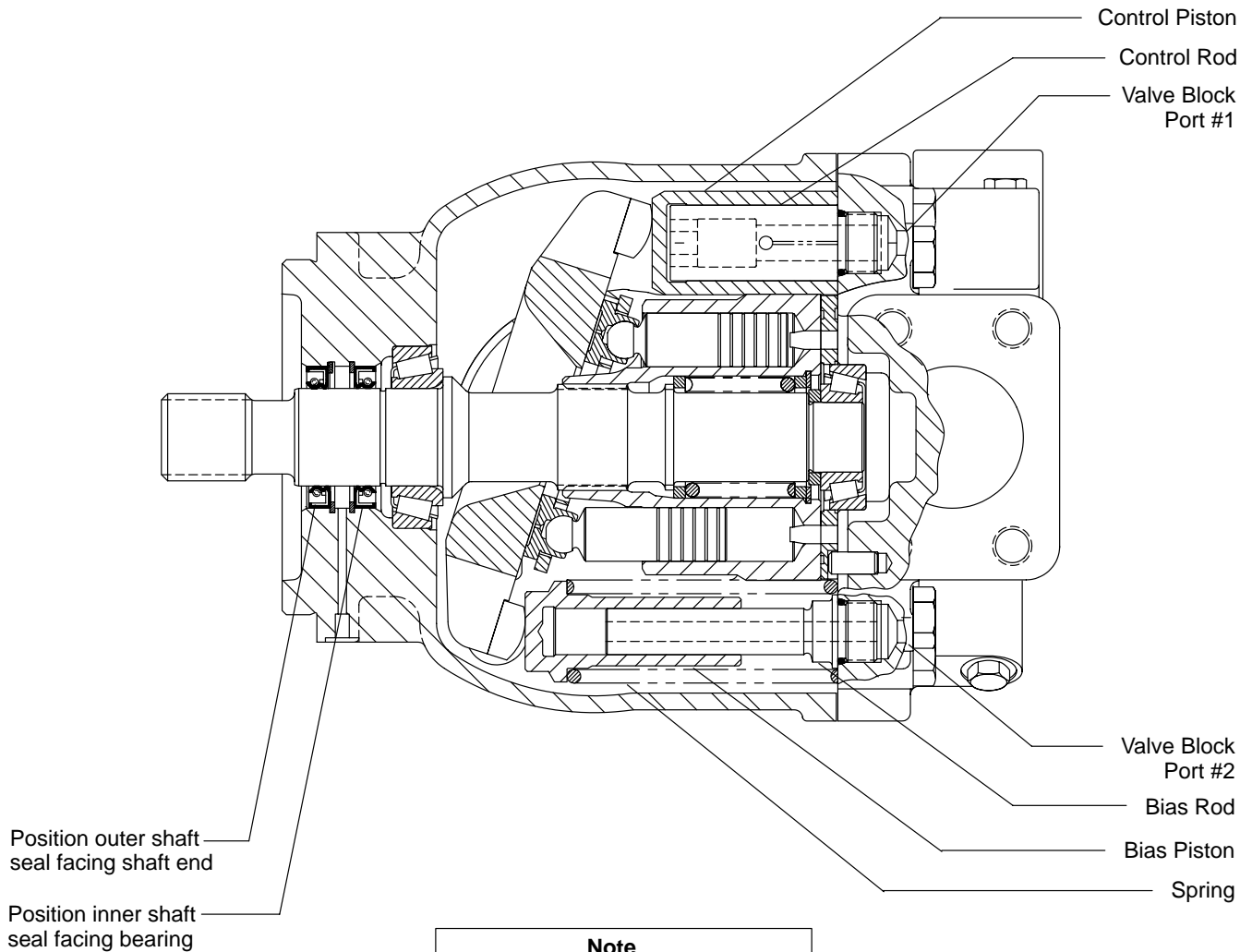

Pump Startup

Make sure the reservoir and circuit are clean and free of dirt and debris prior to filling with hydraulic fluid.

Fill the reservoir with filtered oil to a level sufficient to prevent vortexing at suction connection to pump inlet. It is good practice to clean the system by flushing and filtering using an external slave pump.

Before starting the pump, fill with fluid through one of the ports. This is particularly important if the pump is above the fluid level of the reservoir.

When initially starting the pump, remove all trapped air from the system. This can be accomplished by loosening the pump outlet fittings or connections before starting the pump, or by using an air bleed valve. All inlet connections must be tight to prevent air leaks.

Once the pump is started, it should prime within a few seconds. If the pump does not prime, check to make sure that there are no air leaks in the inlet line and connections. Also check to make sure that trapped air can escape at the pump outlet.

After the pump is primed, tighten the loose outlet connections, then operate for five to ten minutes (unloaded) to remove all trapped air from the circuit. If reservoir has a sight gage, make sure the fluid is clear—not milky.

Add fluid to the reservoir up to the proper fill level.

Model Code

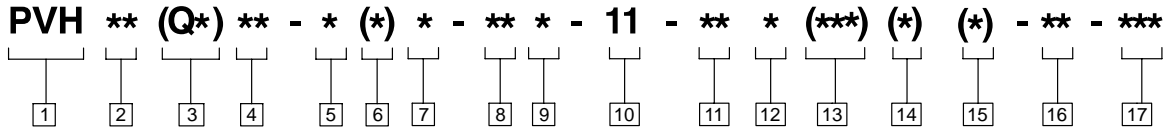

1 Piston pump, variable displacement

2 Maximum geometric displacement

131 - 131.1 cm³/r (8.0 in³/r)
141 - 141.6 cm³/r (8.64 in³/r)

3 Application style

Blank - Mobile application (rated speed & 250/280 bar (3600-4000 psi) pressures)

QI - Quiet industrial application (1500 - 1800 rpm & 250/280 bar (3600-4000 psi) pressures)

QP - Quiet power unit application (1800 rpm & 140 bar (2000 psi) max. pressures – R.H. rotation only)

4 Mounting flange, prime mover end

C - SAE “C” 4-bolt type (SAE J744-127-4)

C3 - Optional 4-bolt SAE-C pilot for vertical pump mounting

5 Shaft rotation, viewed at prime mover end

R - Right hand, clockwise

L - Left hand, counterclockwise

6 Configuration

Blank - Non-thru-drive (single pump)

A - SAE-A thru-drive pump, standard (SAE J744-82-2)

B - SAE-B thru-drive pump, optional (SAE J744-101-2/4)

C - SAE-C thru-drive pump, optional (SAE J744-127-2/4)

S - Adjustable maximum volume stop (“S” option not available on thru-drive and torque control pump models.)

7 Main ports

F - SAE 4-bolt flange ports (standard)

M - SAE 4-bolt pads with metric mounting bolt threads

8 Shaft-end type, at prime mover end

2 - SAE-C 14 tooth spline

3 - SAE-CC 17 tooth spline

12 - SAE-D 13 tooth spline

13 - SAE-CC straight keyed

16 - SAE-D straight keyed

9 Shaft seal, prime mover end

S - Single, one-way

D - Double, two-way

10 Pump design number

11 - (Subject to change. Installation dimensions unaltered for design numbers 10 to 19 inclusive.)

11 Pressure control type

C - Compensator, 140-280 bar (2000-4000 psi)

CM - Compensator, 35-140 bar (500-2000 psi)

IC - CETOP 3 interface compensator, 20 bar factory “differential” pressure setting (QI and QP models only)

12 Factory compensator pressure setting

Blank - Leave blank for “IC” controls only

7 - 70 bar (1015 psi) normal “CM7” setting (all pump sizes)

23 - 230 bar (3335 psi) normal “C23” setting (63, 81, 106, 141 models)

25 - 250 bar (3625 psi) normal “C25” setting (57, 74, 98, 131 models)

13 Optional pressure control functions

Blank - Leave blank for basic compensator controls of IC models.

V - Load sensing, 20 bar (290 psi) factory “differential” pressure setting

T - Torque limiting control (Used with sections **14** and **15** .

VT - Load sensing with torque limiting

VB - Load sensing with internal bleed down (0.15” dia. orifice)

VBT- Load sensing with internal bleed down and torque limiting

14 Torque limiting control pressure setting

Blank - Leave blank if no torque limiting control is used

4 - Standard minimum 40 bar setting of “T” torque control option

15 Torque limiting control summation

Blank - Standard torque control

S - Optional torque control with summation feature

16 Control design number

31 - All control options

17 Special feature suffix

031- Mounting with SAE-A, 2-bolt cover plate

Eaton Hydraulics

15151 Highway 5
Eden Prairie, MN 55344
Telephone: 612 937-7254
Fax: 612 937-7130
www.eatonhydraulics.com

46 New Lane, Havant
Hampshire PO9 2NB
England
Telephone: (44) 170-548-6451
Fax: (44) 170-548-7110

